

# 151S 外径溝入れ 突切り

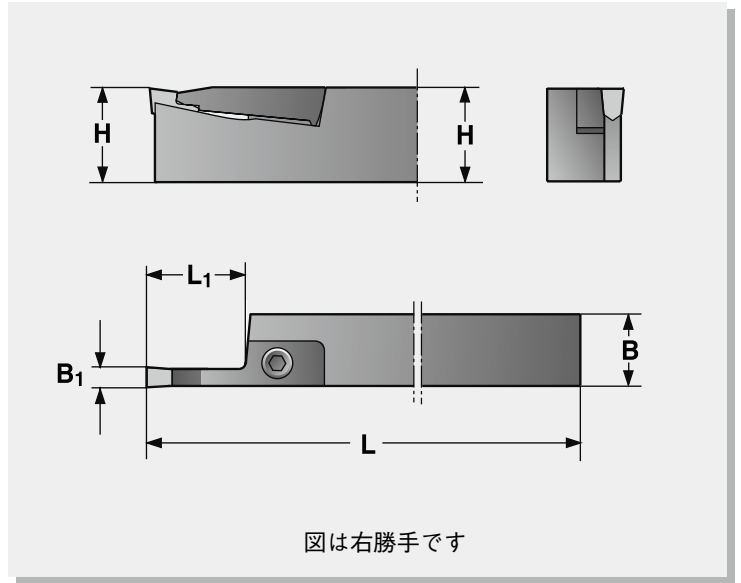
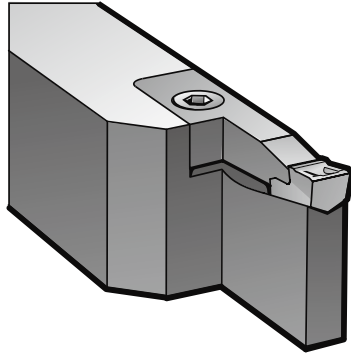

適用チップ	型番		在庫	単価	寸法 (mm)					クランプ		クランプ スクリュー	スプリング	レンチ
	R/L 151S	R151S			H	B	L	L1	B1	R151S 用 SHR	L151S 用 SHL			
3	R/L 151S-2020 × 16 × 3T	○	18,600	20	20	125	16	3	SHR 163F	SHL 163F	F6S-415	—	NY 2.5	
	R/L 151S-2020 × 20 × 3	○	19,570	20	20	125	20		SHR 203M	SHL 203M	F6S-418	BF 04M		
	R/L 151S-2516 × 13 × 3	○	21,140	25	16	140	13		SHR 133	SHL 133	F6S-411	—		
	R/L 151S-2516 × 20 × 3	◎	21,870	25	16	140	20	3	SHR 203M	SHL 203M	F6S-418	BF 04M		
	R/L 151S-2525 × 20 × 3	◎	21,500	25	25	150	20							
	R/L 151S-3225 × 20 × 3	◎	23,670	32	25	170	20							
4	R/L 151S-2012 × 20 × 4	◎	18,120	20	12	125	20	4-4.5	SHR 204MT	SHL 204MT	F6S-418	BF 04M	NY2.5	
	R/L 151S-2020 × 20 × 4	◎	19,570	20	20	125	20							
	R/L 151S-2516 × 20 × 4	◎	21,870	25	16	140	20							
	R/L 151S-2525 × 20 × 4	◎	21,500	25	25	150	20							
5	R/L 151S-2020 × 20 × 5	◎	19,570	20	20	125	20	5	SHR 205MT	SHL 205MT	F6S-418	BF 04M	NY2.5	
	R/L 151S-2516 × 20 × 5	◎	21,870	25	16	140	20							
	R/L 151S-2525 × 20 × 5	◎	21,500	25	25	150	20							
6	R/L 151S-2516 × 20 × 6	◎	21,870	25	16	140	20	6-7.5	SHR 206MT	SHL 206MT	F6S-418	BF 04M	NY2.5	
	R/L 151S-2525 × 20 × 6	◎	21,500	25	25	150	20							
	R/L 151S-3225 × 20 × 6	◎	23,670	32	25	170	20	6-7.5	SHR 326MT	SHL 326MT	F6S-519	BF 05M	NY3	
	R/L 151S-3225 × 32 × 6	◎	25,600	32	25	170	32							
8	R/L 151S-2525 × 20 × 8	◎	27,900	25	25	150	20	8-9	SHR 208MT	SHL 208MT	F6S-519	BF 05M	NY3	
	R/L 151S-3225 × 20 × 8	◎	29,350	32	25	170	20							
	R/L 151S-3225 × 30 × 8	◎	30,800	32	25	170	30	8-9	SHR 308MT	SHL 308MT	F6S-519	BF 05M	NY3	
	R/L 151S-4032 × 40 × 8	◎	36,230	40	32	200	40							
	<sup>1)</sup> R/L 151S-4032 × 50 × 8	○	38,770	40	32	200	50							SHN 8T
10	R/L 151S-3225 × 30 × 10	◎	30,920	32	25	170	30	10-11	SHR 3010MT	SHL 3010MT	F6S-519	BF 05M	NY3	
	R/L 151S-4032 × 30 × 10	○	36,230	40	32	200	30							
	<sup>1)</sup> R/L 151S-4032 × 50 × 10	○	38,640	40	32	200	50							SHN 10T
12	<sup>1)</sup> R/L 151S-4032 × 50 × 12	○	39,610	40	32	200	50	12	SHN 12T		F6S-519	BF 05T	NY3	

注文例：R151S-2525 x 20 x 5 1本

◎：左右両勝手在庫 ○：右勝手のみ在庫 空欄：メーカー（海外）または受注生産

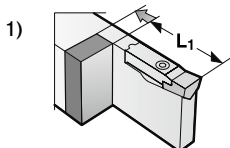

1)ホルダを修正することにより、より深い切込が可能です。

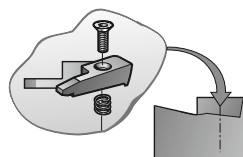

レンチ以外のパーツはホルダに付属しています。