

OM-EN-EB3P-3.10

April 1, 2021

EcoBooster[®]

Operation Manual

Type **EB3P**

FUJI BC
ENGINEERING

Contents

FOR YOUR SAFETY	3P
SPECIFICATION	4P
SET UP OF OIL DETECTOR	4P
RECOMMENDED TOOLS	5P
HOW TO USE	6-7P
CONFIGURATION OF INNER PRESSURE CONTROL SWITCH	8-9P
EB3P TYPE SELECTION GUIDE	10P
RECOMMENDED LUBRICANTS	11P
WARRANTY	11P
CONTACT	11P
SUPPLEMENTALY DRAWING	
Assembly	12P
Flow sheet	13P
Parts list	14P
Wiring	15P
Terminal block layout	16P
DIGITAL PRESSURE SWITCH OPERATION MANUAL	17-21P

FOR YOUR SAFETY

 **WARNING** Improper use of the equipment may cause serious injury or death.

 **CAUTION** Improper use of the equipment may cause injury or material damages.



- EcoBooster is the device for Micro lubrication system to cut metals.
Do not use for other purposes.
- When flammable oil such as volatile oil is used, it may catch a fire.
- Air pressure should be less than 0.7MPa. When it was over 0.7 MPa, it may damage tubing and other devices.
- Do not expose to a material, such as strong acid, strong alkali, corrosive gas.
They may damage tubing and other devices.



- Use Bluebe LB-1, LB-7, or LB-10 type oil. When other oil is used, it may damage the device.
- Do not fill the oil over H line. Drain the overflow oil from the drain valve.

Background Information

EcoBooster has been specifically designed to dispense controlled amount of Bluebe oil for variety of machining applications. Use of non-genuine oil in the system may result in damage to the unit.

SPECIFICATION

○ <u>Maximum working pressure</u>	<u>0.7 MPa</u>
○ <u>Working pressure range</u>	<u>0.4 ~ 0.7 MPa</u>
○ <u>Tank capacity</u>	<u>1,200mL</u>
○ <u>Oil consumption</u>	<u>2 ~ 20 mL/hour (Depend on use condition)</u>
○ <u>Pump strokes</u>	<u>1 Hz (recommendation)~ 3 Hz (Max)</u>
○ <u>Mounting</u>	<u>M6 (2 holes)</u>
○ <u>Mist outlet</u>	<u>1 place (Φ12 tube connector)</u>
○ <u>For input connect</u>	<u>OIL DETECTOR (in Tank)</u>
○ <u>For output connect</u>	<u>EB OPERATION SOLENOID VALVE</u>
○ <u>Dry weight</u>	<u>8kg</u>

SET UP OF OIL DETECTOR

Oil level may vary due to the change of air pressure and other reasons. Specific gravity of oil may also change due to the volume of air in the oil. Under these conditions, the use of "timer" is highly recommended. Alarm signal of oil detector (float switch) shall be activated only when the signal stays at the same condition for a certain period.

Recommendation of timer set up: 10 minutes for EB3P

RECOMMENDED TOOLS

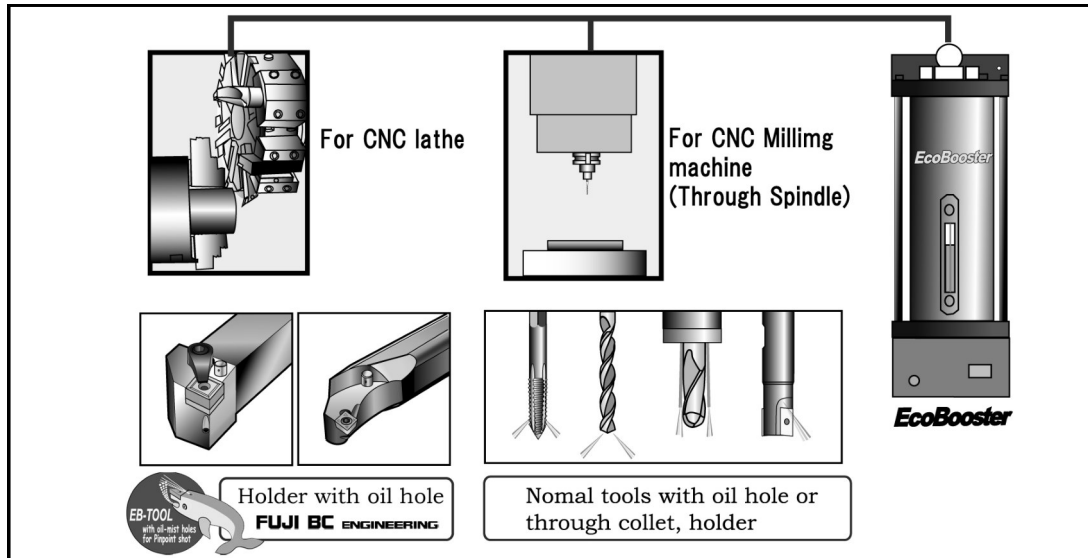

Cutting tool / Holder	Total cross section area
Gap(sukima) through	0.5 mm ² < Total cross sectional area < 5.0 mm ²
Collett through nozzle	
Drill with oil hole	
Tap with oil hole	
Milling tool with oil hole	
Bluebe EB-TOOL	Optimized for EcoBooster

One hole		Two holes	
ΦD	mm ²	ΦD	mm ²
Φ0.4	0.13	Φ0.4	0.25
Φ0.5	0.20	Φ0.5	0.40
Φ0.6	0.28	Φ0.6	0.56
Φ0.7	0.38	Φ0.7	0.76
Φ0.8	0.50	Φ0.8	1.00
Φ0.9	0.63	Φ0.9	1.26
Φ1.0	0.78	Φ1.0	1.56
Φ1.1	0.95	Φ1.1	1.90
Φ1.2	1.13	Φ1.2	2.26
Φ1.3	1.33	Φ1.3	2.66
Φ1.4	1.54	Φ1.4	3.08
Φ1.5	1.77	Φ1.5	3.54
Φ1.6	2.02	Φ1.6	4.04
Φ1.7	2.27	Φ1.7	4.54
Φ1.8	2.54	Φ1.8	5.08
Φ1.9	2.83	Φ1.9	5.66
Φ2.0	3.14	Φ2.0	6.28
Φ2.2	3.80	Φ2.2	7.60
Φ2.4	4.52	Φ2.4	9.04
Φ2.6	5.30	Φ2.6	10.6
Φ2.8	6.10	Φ2.8	12.3
Φ3.0	7.10	Φ3.0	14.1
Φ3.2	8.00	Φ3.2	16.1



Recommended oil hole diameter

Dry mist does not adhere to the inside of piping or spindle but it must be liquefied at the cutting point. Oil hole diameter need to be between 0.5mm² to 5mm² in diameter to obtain the workable condition of EB3P.

HOW TO USE

PROCEDURE TO FILL THE OIL

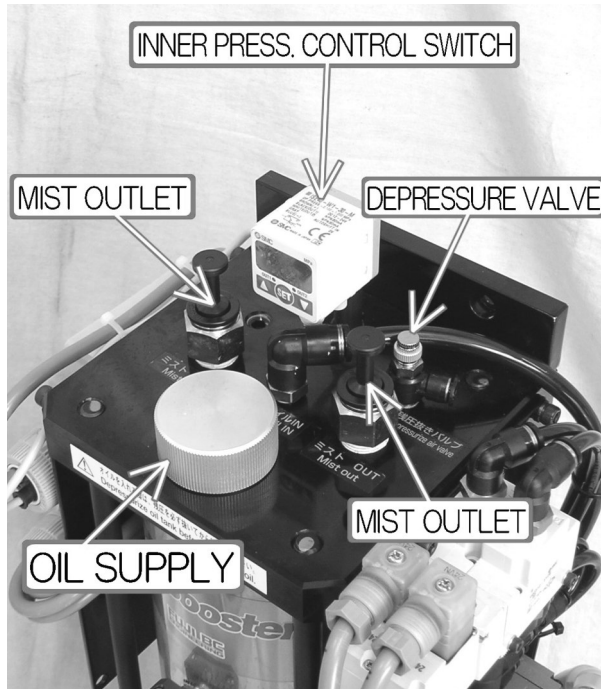

CAUTION
Depressurize oil tank (EB body)
before filling the oil by the
DEPRESSURE VALVE.

1. Please make sure EcoBooster is NOT working before filling lubricant.
2. Release remained pressure in tank to unfasten depressure valve by rotating clockwise.
3. Open reservoir cap. Make sure to prevent any dust from being inside.
4. Supply lubricant to tank.
 - *Depressure valve is opened as air vent.
 - *DO NOT fill lubricant over H level. If lubricant oversupplied, please drain it from drain valve.
5. Close depressure valve to rotate counterclockwise.
6. Close reservoir cap.

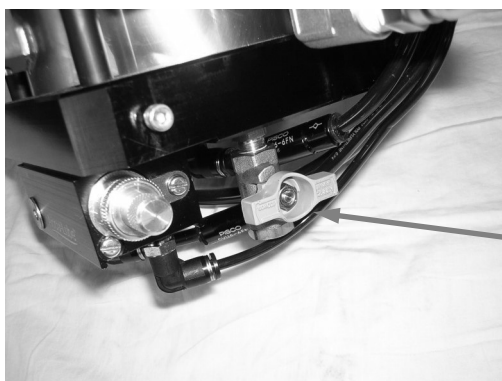

DRAIN VALVE

Air Supply

Maximum working pressure

0.7MPa

Working pressure range

0.4MPa~0.7MPa

Please keep the minimum air pressure while operating the Eco Booster.

To avoid the trouble of the applicator, supply air has to be filtered and water-free also oil-free.

Air Control

a) Mist air

When the solenoid valve for controlling mist air line is ON, it always supplies constant amount of dry mist (micro lubricant droplets).

Inner pressure control switch control the solenoid valve ON/OFF.

See the “CONFIGURATION OF INNER PRESSURE CONTROL SWITCH” to set the pressure switch.

b) Acceleration air

Inner air pressure changes when the size of oil hole of the tool changes. When oil hole get larger, inner air pressure decrease. When inner pressure get lower and need more air to generate dry mist, acceleration air start to work together with the Mist air.

See the “CONFIGURATION OF INNER PRESSURE CONTROL SWITCH” to set the pressure switch.

Caution: If you see white smoke at the tip of the cutting tool, it means the size of oil hole is too big. Make the oil hole smaller or use the higher air pressure. Acceptable size of oil hole is 0.5—5.0 mm²

FREQUENCY GENERATOR

This device controls the speed of the pump cycle. The standard speed of the pump is one stroke per one second. Adjustment is made by changing the position of the indicator using a screw driver. Time the sound interval. Sound of 3 times/sec is for maximum volume and 1 time / 3 sec is for minimum volume of lubricant.

OIL CONSUMPTION

Oil consumption is determined by the combination of frequency generator and oil hole size of the tool. Standard consumption is 4ml per one hour. Oil consumption depends on cutting condition and size of oil hole of tools. From 2ml to 20ml per one hour is normal range of oil consumption.



Key factor to smart use.

Dry Fog does not adhere to the inside of piping or spindle but it must be liquefied to Wet-Mist at the cutting point. Therefore, it is necessary to narrow the tool oil hole, and to liquefy Dry fog. Refer to “Recommended tools” for details.

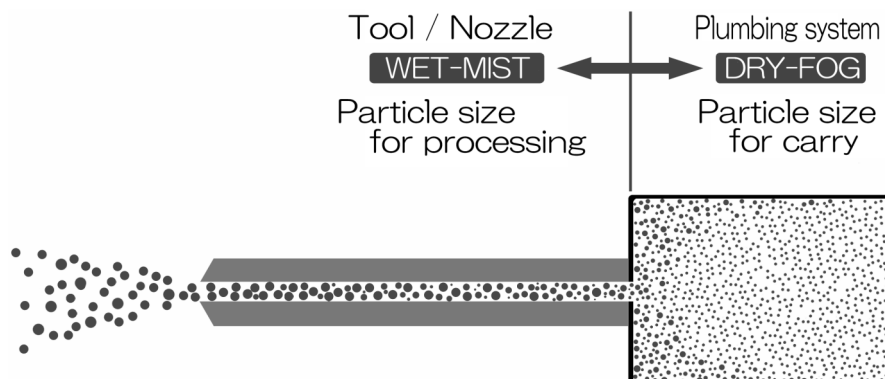

CONFIGURATION OF INNER PRESSURE CONTROL SWITCH

Why Inner Pressure control switch required.

EcoBooster generates dry mist in the unit (chamber) by utilizing difference pressure of supplied air and that of tank inside. Basically, the oil hole of cutting tools has been changed, pressure of tank inside is changed so inner pressure must be maintained with oil holes of cutting tool changed every time. Inner Pressure control switch offers above issue to keep the difference of pressure constant with cutting tools changed.

Here shows pressure switch configuration.

The configuration value depends on supplied air pressure. Please read “How to configure inner pressure switch” in detail.

Example ▶

Air Supply	Acceleration Air OUT1		Mist Air OUT2	
	n_1	H_1	n_2	H_2
0.4 MPa	0.170	0.020	0.185	0.015
0.5 MPa	0.220	0.020	0.235	0.015
0.6 MPa	0.320	0.020	0.335	0.015
0.7 MPa	0.440	0.020	0.435	0.015

Be sure to set the value as indicated according to the given air supply pressure. See the setting procedure at next page.

How to set INNER PRESSURE CONTROL SWITCH

Example for Supply air pressure of 0.5MPa

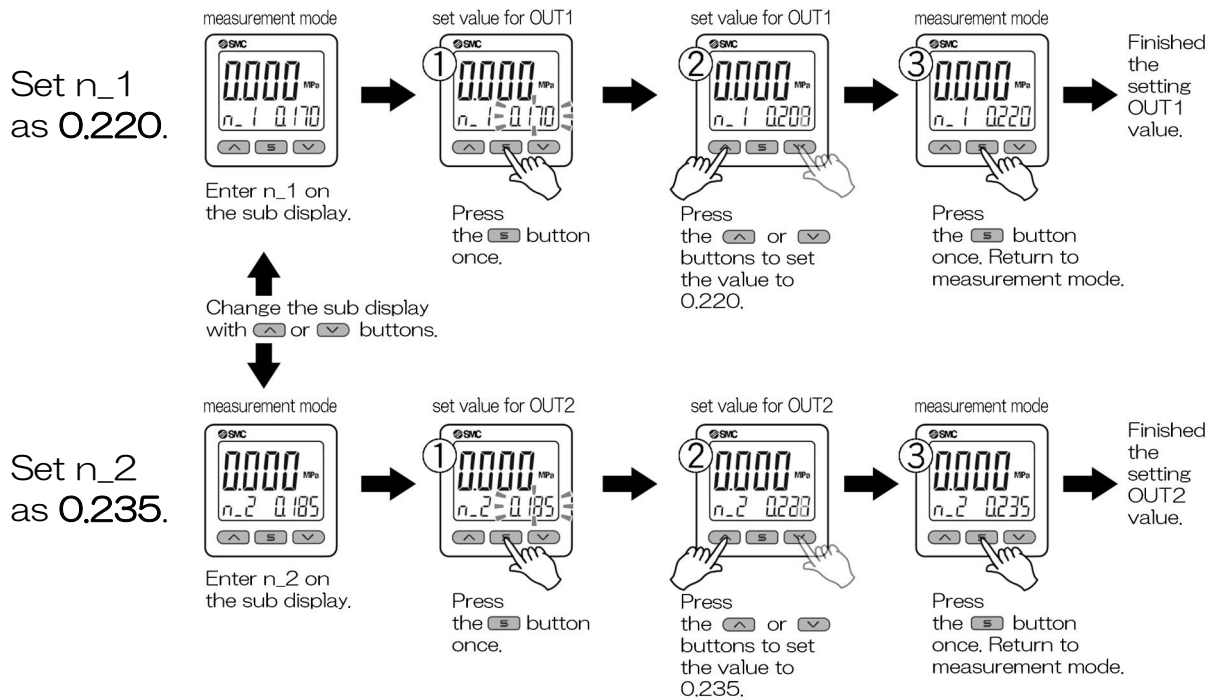

※ Please look at the Digital Pressure Switch operation manual attached at the end.

EB3P TYPE SELECTION GUIDE

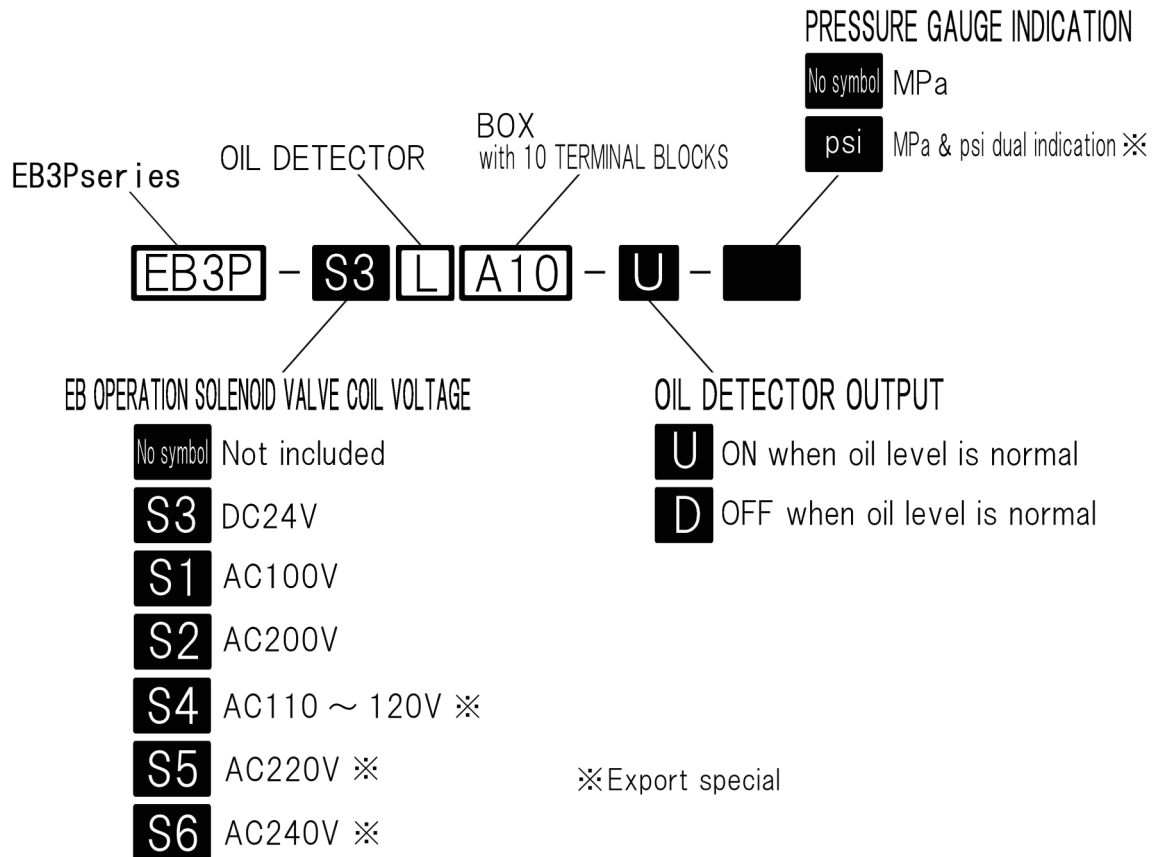

A standard type : EB3P-S3LA10-U

Other types : EB3P-S3LA10-D ,
 EB3P-S1LA10-U , EB3P-S1LA10-D ,
 EB3P-S2LA10-U , EB3P-S2LA10-D ,
 EB3P-LA10-U , EB3P-LA10-D ,
 EB3P-S4LA10-U ※ , EB3P-S4LA10-D ※ ,
 EB3P-S5LA10-U ※ , EB3P-S5LA10-D ※ ,
 EB3P-S6LA10-U ※ , EB3P-S6LA10-D ※ ,
 EB3P-S3LA10-U-psi ※ , EB3P-S3LA10-D-psi ※ ,
 EB3P-S1LA10-U-psi ※ , EB3P-S1LA10-D-psi ※ ,
 EB3P-S2LA10-U-psi ※ , EB3P-S2LA10-D-psi ※ ,
 EB3P-LA10-U-psi ※ , EB3P-LA10-D-psi ※ ,
 EB3P-S4LA10-U-psi ※ , EB3P-S4LA10-D-psi ※ ,
 EB3P-S5LA10-U-psi ※ , EB3P-S5LA10-D-psi ※ ,
 EB3P-S6LA10-U-psi ※ , EB3P-S6LA10-D-psi ※

Types not mentioned above are applicable only for the machine manufacturer.

RECOMMENDED LUBRICANTS

Viscosity of oil is important factor to generate micro lubricant droplets. Also from the safer work condition view point, we recommend the following oil to use.

Bluebe LB-1, LB-7, or LB-10 (in JAPAN)
Accu-lube LB-2000 or LB-6000 (in USA, Europe)

WARRANTY

EcoBooster is backed with One-year Limited Warranty against defects in workmanship and/or materials. Warranty applies only when used under normal operating conditions. Warranty does not applied if a lubricant other than recommended oil is used.

CONTACT

JAPAN FUJI BC ENGINEERING CO., ltd.
3-1, Shioiricho, Mizuho-ku, Nagoya, 467-0851 JAPAN
TEL: 81-52-819-5411 FAX: 81-52-819-5410 www.fuji-bc.com

USA ITW PROBRANDS
805 E. Old 56 Hwy Olathe, Kansas 66061
4647 Hugh Howell Rd. Tucker, Georgia 30084
616 East Industrial St. DeWitt, Iowa 52742
TEL: 1-770-243-8800 FAX: 1-770-243-8899 www.itwprobrands.com

GERMANY ACCU-LUBE MFG. GMBH
Postfach 80 D-75433 Maulbronn, Germany
TEL: 66-7043-5612 FAX: 66-7043-907098 www.accu-lube.com

CHINA BLUEBE(SHANGHAI)ENVIRONMENTAL TECHNOLOGY CO., LTD.
Room716-717, No.3, Lane no.58, East Xinjian Road, Minhang Shanghai,
201100, China
TEL: 86-21-6427-3096 FAX: 86-21-6427-2373

TAIWAN KANDO GROUP CORPORATION
7F, No.8 Lane 83, Sec. 1, Guang Fu Road, San Chung City,
Taipei Hsien 242 Taiwan R.O.C.
TEL: 886-2-2999-0393 FAX: 886-2-2999-0856

KOREA HANSUNG GT CO., LTD.
Gunpocheomdansaneop 1-ro 39, Gunpo-si, Gyeonggi-do, 15881
South Korea
TEL: 82-31-428-8250 FAX: 82-31-455-0487

THAILAND THAI WORTH CO., LTD.
2/9 Serithai Road, Kwaeng Kannayao, Khet Kannayao, Bangkok
10230 Thailand
TEL: 66-2736-4560 FAX: 66-2736-4694

SINGAPORE KEMET FAR EAST PTE.,LTD.

MALAYSIA 32, Ang Mo Kio Industrial Park 2, #02-12, Sing Industrial Complex,

INDONESIA 569510 Singapore

PHILIPPINES TEL: 65-64820990 FAX: 65-64811363

VIETNAM

INDIA ITW INDIA PRIVATE LIMITED
Plot No.34 to 37, Phase-2, IDA, APIIC, Pashamylaram,
Medak Dist, 502307 India
TEL: 91-8455-224700 FAX: 91-8455-224705

Accessories:
Union Y Φ12 Tubes (Connect to Mist outlet)

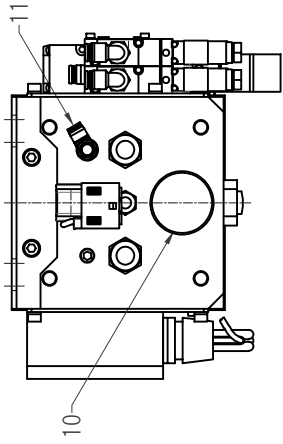
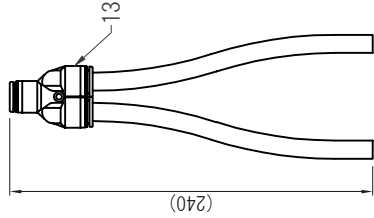

Mist Outlet
Φ12 Tube Fitting

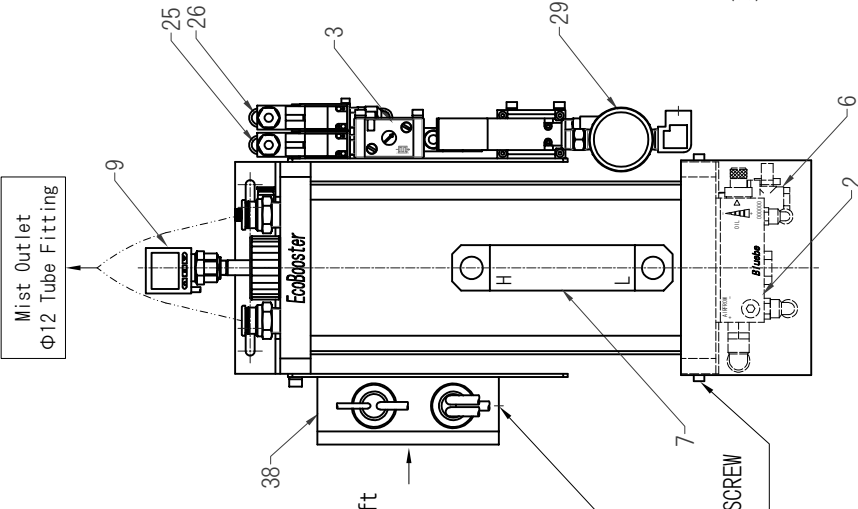

Keep enough room left to use screw driver to open/close terminal box.

1-φ21 for Customer

3-M4 CAP SCREW for Cover

Install and keep EcoBooster vertically.
Keep enough room on the top and bottom of EcoBooster to fill lubricant, set piping, remove bottom cover and drain lubricant.

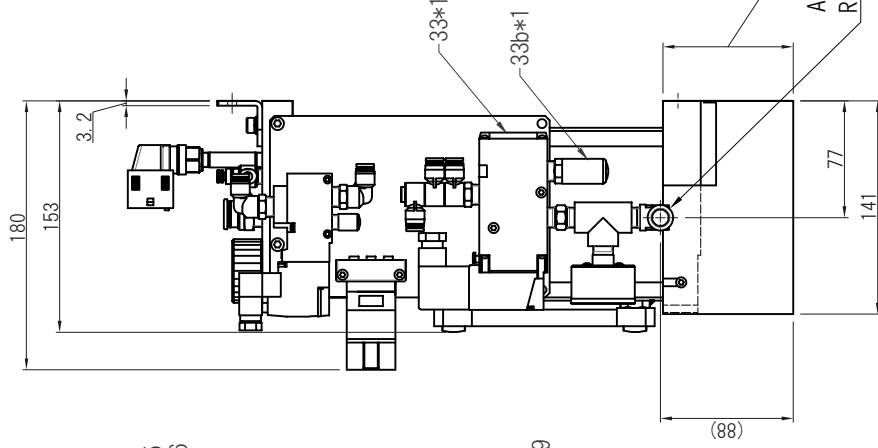
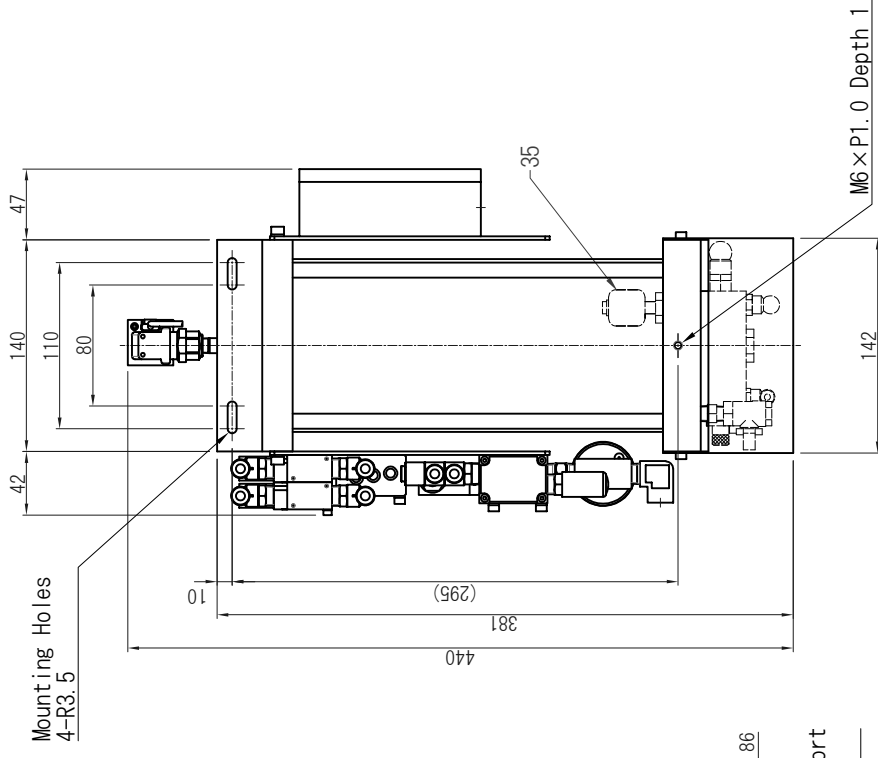

*1) Solenoid valves (Item 33 and 33b) to operate EB are not equipped when model number does not offer "SQ".

PAPER SIZE : A 4

REVIEWS		DATE	DESIGNED	DRAWN	CHECKED	APPROVED	TITLE	
		' 20.09.10	INOUE	技術 '20.09.11 前田	技術 '20.09.11 前田	部長 '20.09.17 平山	EcoBooster EB3P Outline	
							SCALE	DRAWING CODE
							3RD ANGLE PROJECTION	EN-EB3P-01-STD3.10

※105 We recommend to install Rotary Valve [Full Boa Type].

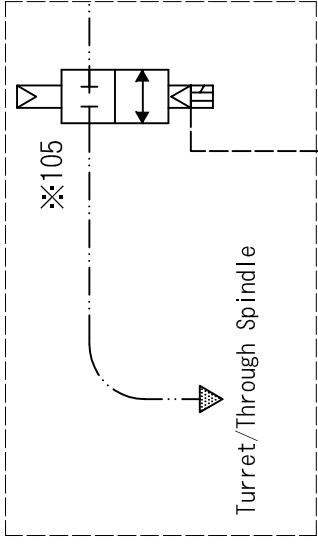

--- Air
 --- Oil
 --- Mist

□ OR ※ Prepare them by the customer.

Prepare them by the customer.

Air supply
 Recommend pressure 0.6MPa
 Max. pressure 0.7MPa
 Min. pressure 0.4MPa
 Max. flow 350L/min[ANR]

Supply filtered clean air.

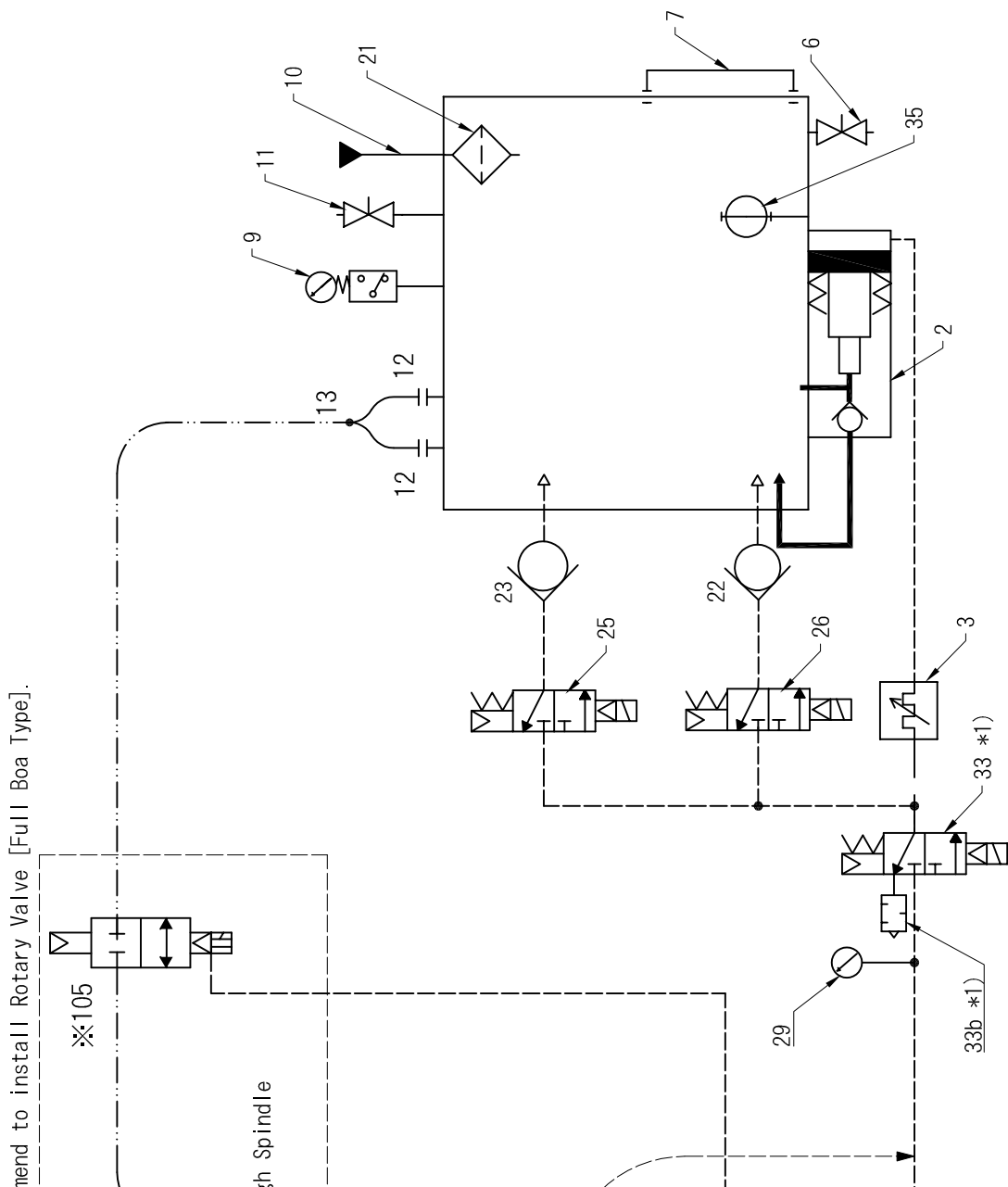
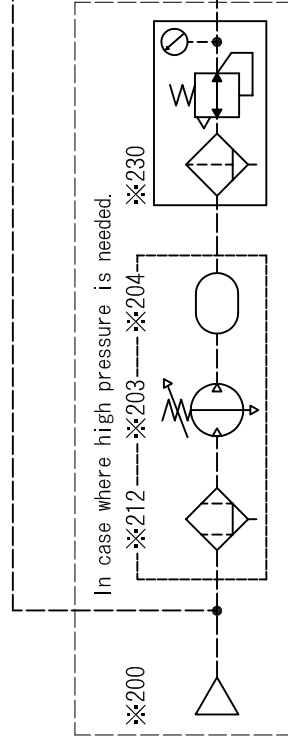

※ They are not included in EcoBooster.

*1) Solenoid valves (Item 33 and 33b) to operate EB are not equipped when model number does not offer "S□".

PAPER SIZE : A 4

REVIEWS		DATE	DESIGNED	DRAWN	CHECKED	APPROVED	TITLE
		' 18. 06. 06	INOUE	MAENO	SAKAI	GOTO	EcoBooster EB3P Flow Sheet
							SCALE
							DRAWING CODE
							EN-EB3P-02-STD3. 01

EcoBooster EB3P Parts List

Drawing Code: EN-EB3P-03-STD3.10

'20.09.10

No.	ITEM	Q'ty	MAKER	TYPE	REMARKS
2	FK PUMP	1	FUJI BC	9722EB3	
3	FREQUENCY GENERATOR	1	FUJI BC	9707	
6	DRAIN	1	KITZ	TKT1/8	
7	OIL LEVEL GAUGE	1	KYOWA	KHR-120A-M10	
9	INNER PRESS. CONTROL SW	1	SMC	ISE20C-X-M-C01L-W	2 NPN OUTPUT
10	OIL SUPPLY	1	FUJI BC	101MP1001	D42 x M27
11	DEPRESSURE VALVE	1	PISCO	JNC6-01	
12	MIST OUTLET	2	PISCO	PC12-03	
13	UNION Y	1	PISCO	PY12	
21	OIL FILTER	1	FUJI BC	102TNK2103	
22	CHECK VALVE	1	PISCO	CVU6-6FN	MIST AIR LINE
23	CHECK VALVE	1	PISCO	CVU6-6FN	ACCELERATION AIR LINE
25	SOLENOID VALVE(AIR ACCELERATION)	1	SMC	VQZ312-5YZB1-02	DC24V
26	SOLENOID VALVE(MIST AIR)	1	SMC	VQZ312-5YZB1-02	DC24V
29	PRESSURE GAUGE	1	SMC	G46-10-02	Air supply
33	EB OPERATION SOLENOID VALVE ※	1	SMC	VP542K-5DUE1-02A VP542K-1DZE1-02A VP542K-2DZE1-02A	DC24V AC100V AC200V
33b	SILENCER ※	1	SMC	AN200-02	
35	FLOAT SWITCH(OIL DETECTOR)	1	NOHKEN	OLV-5	
38	TERMINAL BOX	1	TOYOGIKEN	BOXTM-1002	10 TERMINAL BLOCKS
41	ACCELERATION AIR BYPASS VALVE	1	PISCO	JNC6-01	
				Prepare it by the customer.	
105	Rotary valve (Air operated type 2 port valve)		CKD	CHB-V1-10-0L-□ (□ : Coil voltage)	(We recommend it.)
200	Air supply				
203	Booster regulator		SMC	VBA40A-04GN	''
204	Air tank		SMC	VBAT20A1-V	''
212	Mist separator		SMC	AFM30-03C-2-A	''
230	Filter regulator		SMC	AW30-03CG-2-B	''

※Solenoid valves (Item 33 and 33b) to operate EB are not equipped when model number does not offer “S□”.

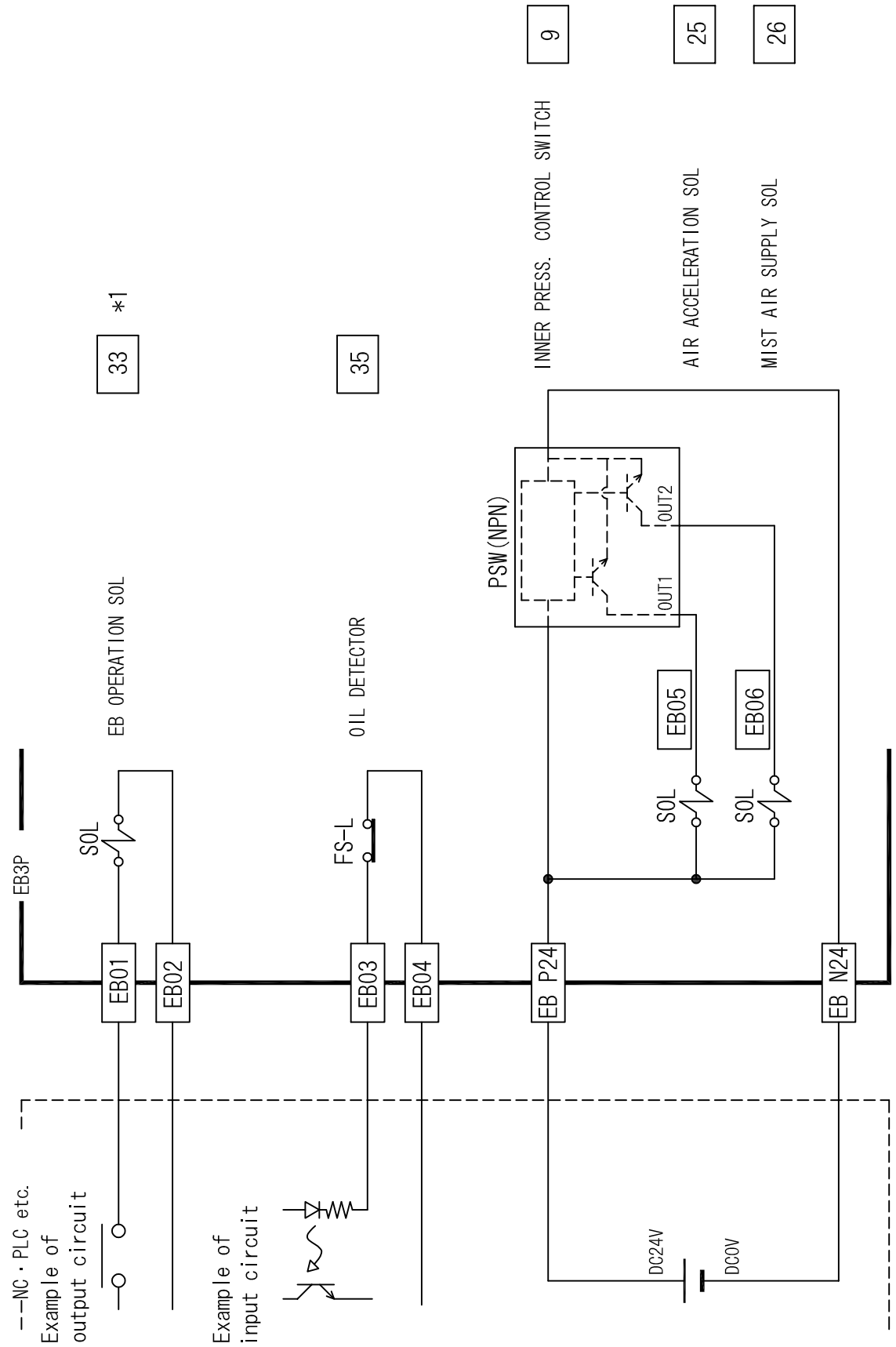

33 *1

35

9

25

26

INNER PRESS. CONTROL SWITCH

AIR ACCELERATION SOL

MIST AIR SUPPLY SOL

*)Wiring of each device connect to terminal box.

The number in the square shows the product number in the drawing.

*1) Solenoid valves (Item 33) to operate EB are not equipped when model number does not offer "S□".

DATE	DESIGNED	DRAWN	CHECKED	APPROVED	TITLE
'18.01.17	INOUE	MAENO	SAKAI	GOTO	EcoBooster EB3P wiring
					SCALE
					DRAWING CODE
FUJIBO ENGINEERING CO., LTD					3RD ANGLE PROJECTION
					FREE (NTS)
					EN-EB3P-04-STD3.00

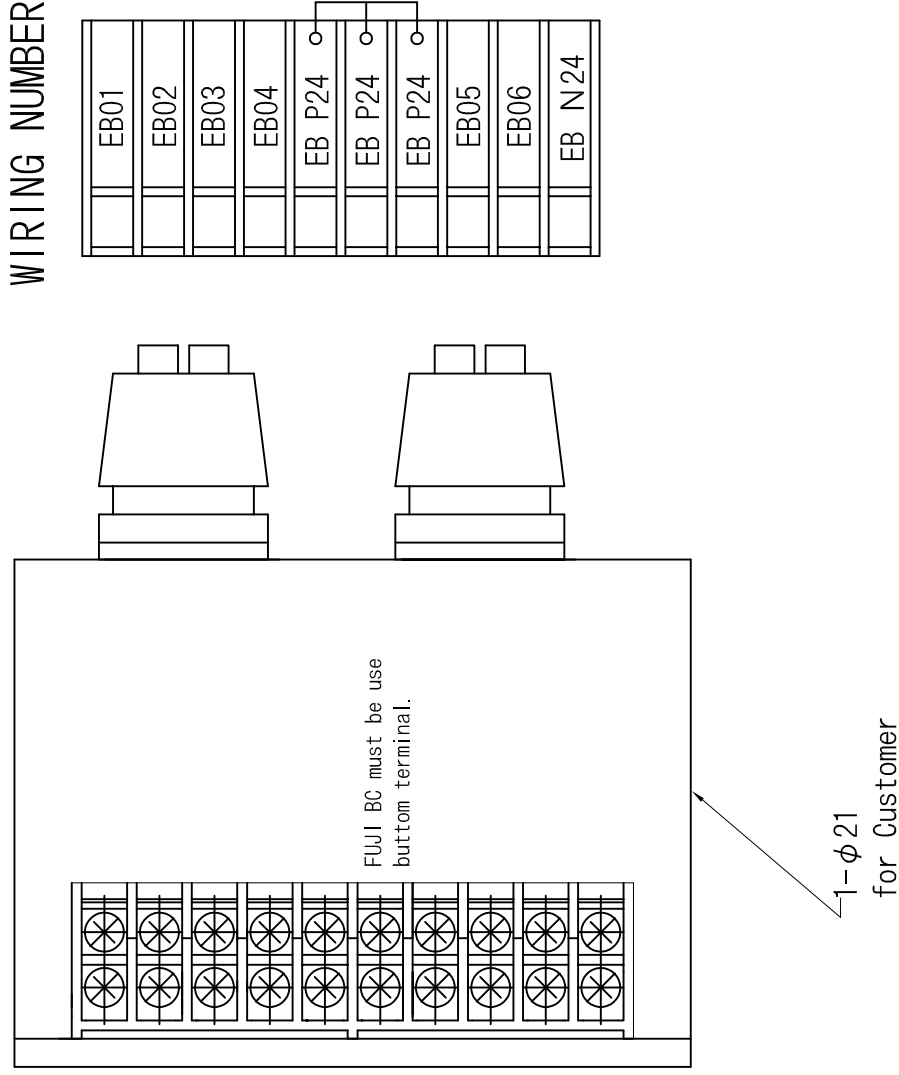

WIRING NUMBER

EB01
EB02
EB03
EB04
EB P24
EB P24
EB P24
EB05
EB06
EB N24

EB OPERATION SOL *1

OIL DETECTOR

DC24V (INNER PRESS. CONTROL SWITCH, SOL)

INNER PRESS. CONTROL SWITCH OUT1, ACCELERATION SOL

INNER PRESS. CONTROL SWITCH OUT2, MIST AIR SUPPLY SOL

DC 0V (INNER PRESS. CONTROL SWITCH)

*1) Solenoid valves (Item 33 and 33b) to operate EB are not equipped when model number does not offer "S□".

DATE	DESIGNED	DRAWN	CHECKED	APPROVED	TITLE
'18.01.17	INOUE	MAENO	SAKAI	GOTO	EcoBooster EB3P terminal block layout SCALE
FUJII BC ENGINEERING CO., LTD				3RD ANGLE PROJECTION	FREE (NTS)
					DRAWING CODE
					EN-EB3P-10-STD3.00

Setting of EcoBooster INNER PRESSURE CONTROL SWITCH

Air Supply	Acceleration Air OUT1		Mist Air OUT2	
	n_1	H_1	n_2	H_2
0.4MPa	0.170	0.020	0.185	0.015
0.5MPa	0.220	0.020	0.235	0.015
0.6MPa	0.320	0.020	0.335	0.015
0.7MPa	0.420	0.020	0.435	0.015
※ 0.8MPa	0.520	0.020	0.535	0.015

Example for Supply Air Pressure of 0.4MPa

※ EB7EP AC Solenoid Type and EB3P, EB3EP Maximum Pressure : 0.7MPa

Adapted from SMC Co., Ltd. home page







Model : ISE20C-X/Y-M-C01L-W

Display unit : MPa	OUT1 Output mode : Hysteresis	OUT2 Output mode : Hysteresis
Display color : Normally red	Normal/Reversed Output : Reversed	Normal/Reversed Output : Reversed
	Response time : 1.5ms	Response time : 1.5ms

OUT1 Set value n_1 : 0.170 MPa
Hysteresis H_1 : 0.020 MPa

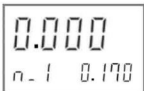















OUT2 Set value n_2 : 0.185 MPa
Hysteresis H_2 : 0.015 MPa

Setting Procedure 1 (3-step setting) The usual procedure. Other settings are set at the shipping time from FUJI BC ENGINEERING.

Mode	Display	Operation procedure
Preparation, measurement mode		Connect 12 to 24 VDC power supply. Go to measurement mode.
Entering the set value [n_1] for OUT1		Enter OUT1 set value [n_1] on the sub display with ▲ or ▼ buttons.
		Press the Ⓢ button once. Go to the setting of set value [n_1] for OUT1. Press the ▲ or ▼ button to change the set value on the right side of the sub display (see left).
		Press the Ⓢ button once. Return to measurement mode.
Entering the set value [n_2] for OUT2		Enter OUT2 set value [n_2] on the sub display with ▲ or ▼ buttons.
		Press the Ⓢ button once. Go to the setting of set value [n_2] for OUT2. Press the ▲ or ▼ button to change the set value on the right side of the sub display (see left).
		Press the Ⓢ button once. Return to measurement mode.
	Settings complete.	

Setting Procedure 2 (Simple setting) Perform this procedure if you have changed the Hysteresis or Response time by mistake.

Setting items : OUT1,OUT2 Set value [n_1,n_2], Hysteresis [H_1,H_2], Response time

Mode	Display	Operation procedure
Preparation, measurement mode		Connect 12 to 24 VDC power supply. Go to measurement mode.
Entering the set value [n_1] for OUT1		Hold down the [SET] button for at least 1 seconds, but no more than 3 seconds [SET] will be shown on the main display.
		Release the button while [SET] is showing on the display. The main display will show the current pressure value and the left sub display will show the set value [n_1]. The set value will be blinking on the right sub display. Go to the setting of set value [n_1] for OUT1.
		Press the ▲ or ▼ button to change the set value on the right side of the sub display (see left).
Setting of hysteresis [H_1] for OUT1		Press the [SET] button once. Go to hysteresis [H_1] settings for OUT1.
		Press the ▲ or ▼ button to change the set value on the right side of the sub display (see left).
Setting response time for OUT1		Press the [SET] button once. Go to response time settings for OUT1.
		Press the ▲ or ▼ button to change the value on the right side of the sub screen (see left).
Entering the set value [n_2] for OUT2		Hold down the [SET] button for at least 1 seconds, but no more than 3 seconds [SET] will be shown on the main display.
		Press the [SET] button once. Go to the setting of set value [n_2] for OUT2.
		Press the ▲ or ▼ button to change the set value on the right side of the sub display (see left).
Setting of hysteresis [H_2] for OUT2		Press the [SET] button once. Go to hysteresis [H_2] settings for OUT2.
		Press the ▲ or ▼ button to change the set value on the right side of the sub display (see left).
Setting response time for OUT2		Press the [SET] button once. Go to response time settings for OUT2.
		Press the ▲ or ▼ button to change the value on the right side of the sub screen (see left).
Measurement mode		Hold the [SET] button for 2 second or longer. Return to measurement mode.
	Settings complete.	

Setting Procedure 3 (Function Settings) Perform this procedure if you have restored SMC default settings.

Setting items : OUT1, OUT2 Output mode, Normal/Reversed output, Set value [n_1, n_2], Hysteresis [H_1, H_2], Response time, Display color



Mode	Display	Operation procedure
Preparation, measurement mode		Connect 12 to 24 VDC power supply. Go to measurement mode.
Function selection mode		Hold down the S button for at least 3 seconds, but no more than 5 seconds [F 0] will be shown on the main display. Release the button when [F 0] is displayed to return to function selection mode.
Display unit settings		Display [F 0] by pressing the \blacktriangle or \blacktriangledown button in function selection mode. Press the S button once. Go to display unit settings.
		Press the \blacktriangle or \blacktriangledown button to change the value on the right side of the sub screen (see left).
		Press the S button once. Return to function selection mode.
Setting output mode for OUT1		Display [F 1] by pressing the \blacktriangle or \blacktriangledown button in function selection mode. Press the S button once. Go to output mode settings for OUT1.
		Press the \blacktriangle or \blacktriangledown button to change the value on the right side of the sub screen (see left).
Setting of normal/reversed output for OUT1		Press the S button once. Go to normal/reversed output settings for OUT1.
		Press the \blacktriangle or \blacktriangledown button to change the value on the right side of the sub screen (see left).
Entering the set value [n_1] for OUT1		Press the S button once. Go to the setting of set value [n_1] for OUT1.
		Press the \blacktriangle or \blacktriangledown button to change the set value on the right side of the sub display (see left).
Setting of hysteresis [H_1] for OUT1		Press the S button once. Go to hysteresis [H_1] settings for OUT1.
		Press the \blacktriangle or \blacktriangledown button to change the set value on the right side of the sub display (see left).
Setting response time for OUT1		Press the S button once. Go to response time settings for OUT1.
		Press the \blacktriangle or \blacktriangledown button to change the value on the right side of the sub screen (see left).

Display color settings

F 1
[oL 15o0

Press the  button once.
Go to display color settings.

F 1
[oL rEd



Press the  or  button to change the value on the right side of the sub screen (see left).

F 1
oUt1 HYS



Press the  button once.
Return to function selection mode.

Setting output mode for OUT2

F 2
oUt2 HYS

Display [F 2] by pressing the  or  button in function selection mode.
Press the  button once.
Go to output mode settings for OUT2.

F 2
oUt2 HYS



Press the  or  button to change the value on the right side of the sub screen (see left).

Setting of normal/reversed output for OUT2

F 2
2oL 2_P

Press the  button once.
Go to normal/reversed output settings for OUT2.

F 2
2oL 2_n



Press the  or  button to change the value on the right side of the sub screen (see left).

Entering the set value [n_2] for OUT2

F 2
n_2 0.500

Press the  button once.
Go to the setting of set value [n_2] for OUT2.

F 2
n_2 0.185



Press the  or  button to change the set value on the right side of the sub display (see left).

Setting of hysteresis [H_2] for OUT2

F 2
H_2 0.050

Press the  button once.
Go to hysteresis [H_2] settings for OUT2.

F 2
H_2 0.015



Press the  or  button to change the set value on the right side of the sub display (see left).

Setting response time for OUT2

F 2
dt2 1

Press the  button once.
Go to response time settings for OUT2.

F 2
dt2 1.5

Press the  or  button to change the value on the right side of the sub screen (see left).

Display color settings

F 2
[oL rEd

Press the  button once.
Move to display colour settings; this is the same as that of OUT1, which has already been set.

F 2
oUt2 HYS

Press the  button once.
Return to function selection mode.

Measurement mode



0.000
n_1 0.170

Hold the  button for 2 second or longer.
Return to measurement mode.

Settings complete.

Zero-clear

0.000
n_1 0.170

Press the  and  buttons simultaneously for around 1 second under atmospheric pressure.
This will reset the displayed value to zero.

■[F99] Reset to default settings



If the product settings are uncertain, the SMC default values can be restored.



<Operation>

Press the  or  button in function selection mode to display [F99].

Press the  button.  Move on to reset to default settings.

Reset to default settings

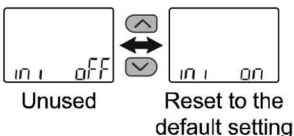
Press the  or  button to select reset to default settings.





Unused Reset to the default setting

[oFF] (not use) is selected
Press the  button to set.

Return to function selection mode.

[on] (reset to default settings) is selected

Press the  and  buttons simultaneously for 5 second or longer.

All settings are returned to the default values. Return to function selection mode.

[F99] Reset to default settings completed

Return to **【Digital Pressure Switch Operation Manual】** 、
Perform Setting Procedure 3 (Function Settings).