

Type **BX**

-MQL Semi-dry External Applicator-

**User's Guide**

-Installation & Operating Instructions-

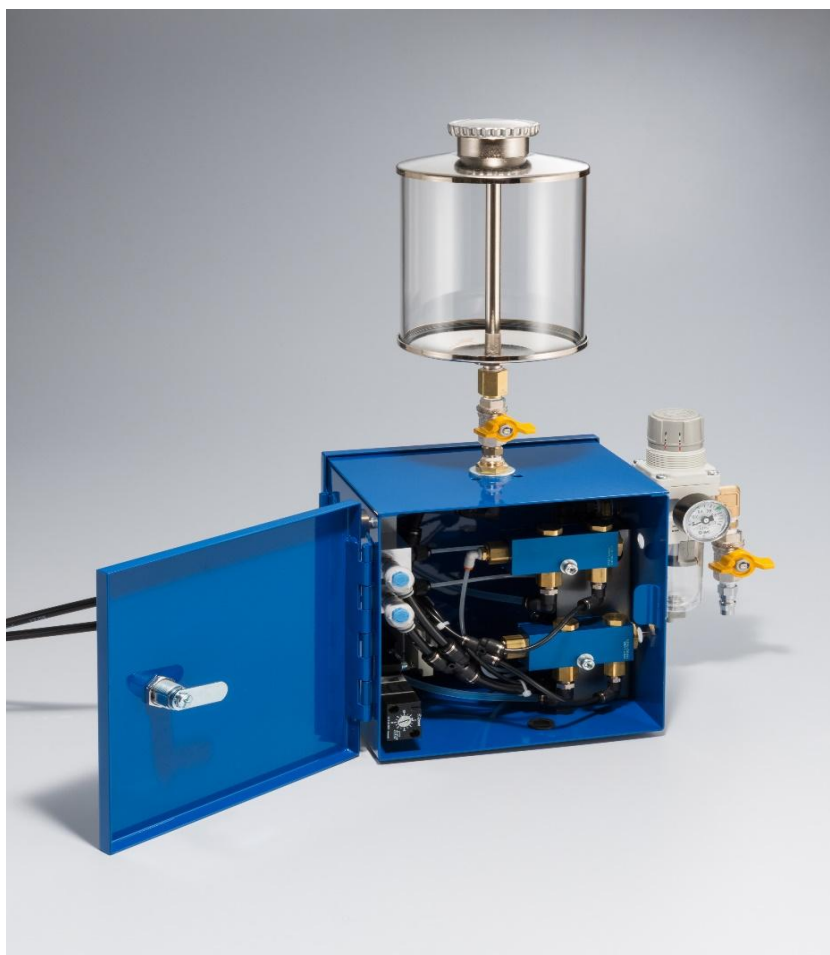

3-1 Shioiri-cho, Mizuho-ku, Nagoya 467-0851 JAPAN.  
[www.fuji-bc.com](http://www.fuji-bc.com)

## INTRODUCING BX TYPE

BX Applicators are positive displacement lubrication systems for Minimum Quantity Lubrication that regulate the amount lubricant applied to a tool's cutting edge in exact quantities.

BX Applicator are designed to accurately deliver a constant, consistent and large amount of lubricant and variable lubricants granted as soluble, straight(neat) oils.

Accuracy and precision year after year to deliver lubricant to the cutting edge each time, every time.

<b>TABLE OF CONTENTS</b>	<b>Pages</b>
Read instructions carefully before use _____	<b>2</b>
For your safety	
Warranty	
Specifications _____	<b>3</b>
Preparing _____	<b>3</b>
Installing _____	<b>3</b>
Components _____	<b>4-5</b>
Operating _____	<b>6-7</b>
Troubleshooting _____	<b>8</b>
External Dimensions _____	<b>9</b>
Diagram _____	<b>10</b>
Parts List _____	<b>11</b>

## READ INSTRUCTIONS CAREFULLY BEFORE USE

### FOR YOUR SAFETY

- USE only genuine lubricant Bluebe LB-Series.

Any other lubricants usage may result in the applicator malfunctioning.

- DO NOT USE low flash point oils such as volatile oils. It would cause an explosion or fire.
- DO NOT disassemble mist applicator. It would cause mist applicator malfunctioning.
- Please make sure machining center is stopped when inspecting mist output.

Manual operating required to run mist unit.

If machining center is NOT stopped, cutting tool and/or mechanical equipment would move.

There is a possibility that workers would get caught in machines.

### WARRANTY

All Products sold carry a ONE-YEAR PARTS WARRANTY by FUJI BC ENGINEERING, only to purchasers for in business or original equipment manufacture, against defects in workmanship or materials under normal business.

Any part which is determined by FUJI BC ENGINEERING, to be defective in material or workmanship and returned to FUJI BC ENGINEERING, will be repaired or replaced at FUJI BC ENGINEERING.

All Warranties, expressed and implied, are null and void if the equipment is subject to improper installation, application, misuse, neglect, and/or accident or if a lubricant other than FUJI BC lubricant, Bluebe is used in the warrantied equipment.

## SPECIFICATIONS

Supported fluid	Clean air (Remove dirt, oil and moisture)
Lubricant	USE ONLY genuine lubricant BLuebe LB series
Supply Air	0.4~0.7 MPa
Air flow	over 120 L/min[ANR] as per one nozzle
Air Inlet port	Rc 1/4
Temperature	5~50°C granted



**Bluebe Genuine Lubricants**

## PREPARING

1. Attach reservoir to the machine.
2. Attach the applicator to the machine, make sure that it is as level as possible.
3. Security box is available to open front and rear side.

Following condition required to maintain mist applicator.

- (1) Please make sure enough room maintained to open front and rear doors.
- (2) DO NOT prevent any piping and wiring from opening both doors.



**Front view**

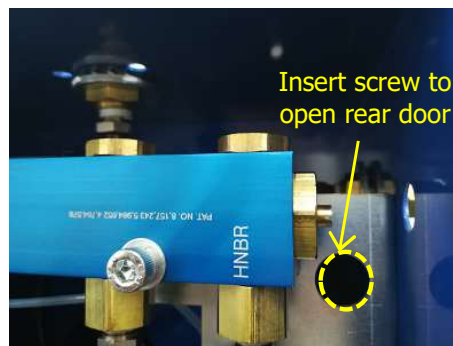

**How to open rear door**



**Rear view**

## INSTALLING

1. Install Reservoir and fill reservoir with lubricant.
  - \*Make sure lubricant level is higher than L line or minimum quantity line.
  - \*Make sure chips and/or other objects do not get into reservoir.
2. Make sure the air supply is connected and then turn the applicator on.
3. Adjust frequency generator to "I" to use a small flat screwdriver.
4. Check lubricant is observed from nozzle and turn air valve control clockwise.
5. Pulling blue knob to unlock air control valve.

Please be noted that it would take time to get lubricant output.

## COMPONENTS

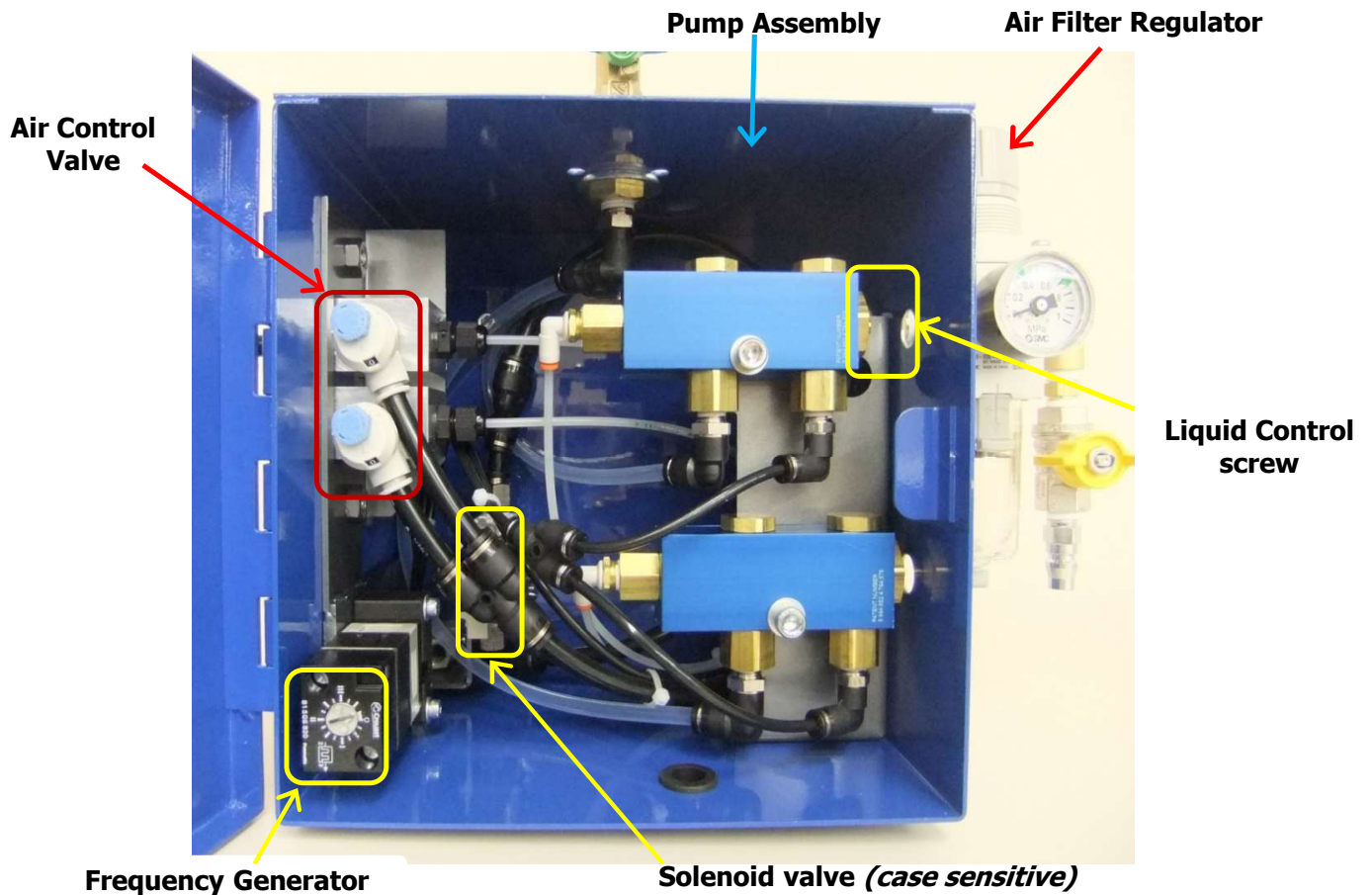

### ■ Air Control Valve

Controls the amount of continuous air supplied to the nozzle.

### ■ Pump Assembly

Uses air pressure to power the pump cycle; provides consistent and accurate lubrication instantly.

### ■ Frequency Generator

Primary lubrication control; regulates the pump cycle.

### ■ Liquid Control screw

Controls quantity of lubricant per pump stroke.

### ■ Liquid Reservoir

1900mL or 4L tank available.

Please make sure lubricant level is higher than L line or minimum quantity line.

If lubricant line is lower than L line, air would be into pump assembly makes it broke.

### ■ Air Filter Regulator/Pressure Gauge

Helps prevent particles and water from entering the applicator through the air supply.

### ■ Electric solenoid valve

Electronic solenoid controls the applicator by regulating airflow.

## ■ Double tube (2 channel system: Lubricant and Air line)

Air Hose(outside): Carries compressed air to the nozzle.

Lubricant Line(inside): Capillary tube that runs inside the air hose.

Air hose will be selected as (O.D.) $\phi$ 10.5 Braided hose,  $\phi$ 8 Soft Nylon tubing or  $\phi$ 10 Soft Nylon tubing.

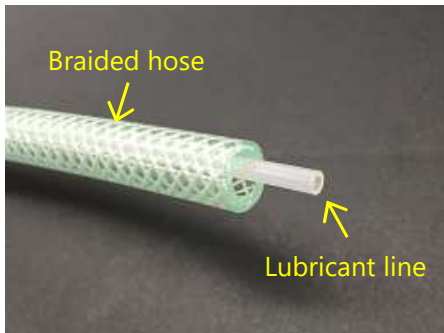

**Dual tube [2 channel system]  
(Braided air hose)**

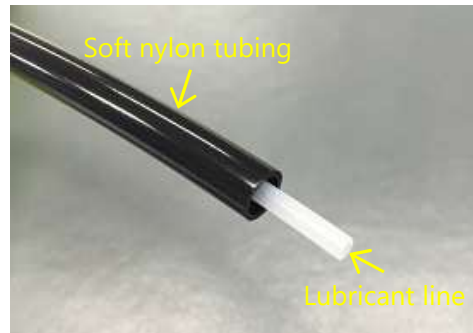

**Dual tube [2 channel system]  
(Soft nylon air tubing)**

## ■ Nozzle

Variable nozzles available.



**Loc-Line nozzle**

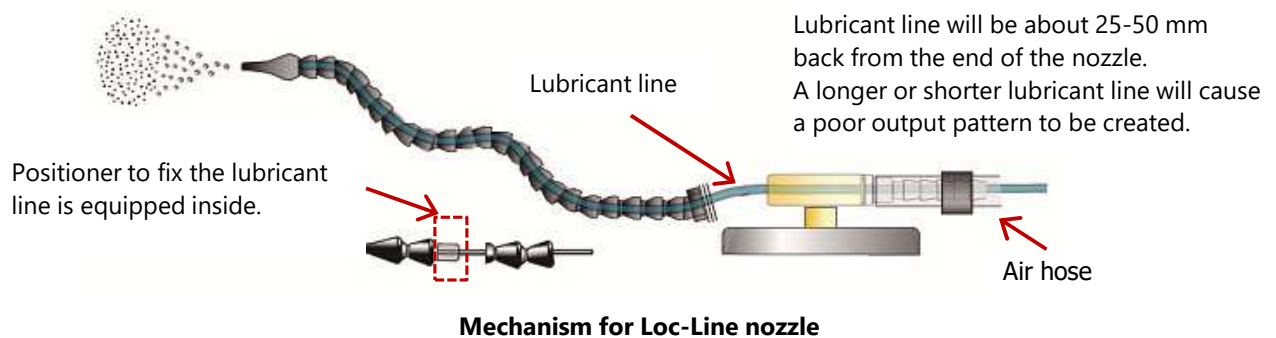

**Mechanism for Loc-Line nozzle**

## OPERATING

### ■ LUBRICANT CONTROL

Lubricant amount control is adjustable to set pump stroke as per one-shot by ①liquid control screw and to regulates the pump cycle by ②frequency generator.

#### ① Liquid Control screw

##### ● How to use

Control quantity of lubricants to turn screw with a small flat screwdriver.

- Counterclockwise to increase
- Clockwise to decrease

##### ● Notes

Shipping State: Maximum pump stroke (turned counterclockwise).

DO NOT use the pump state with screws turned about 7 or 8 times.

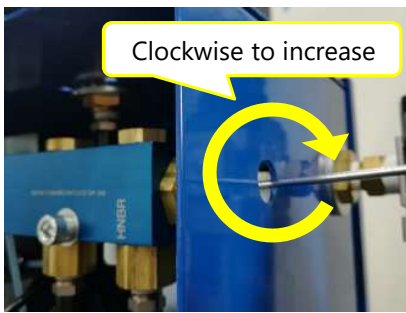

How to set pump stroke

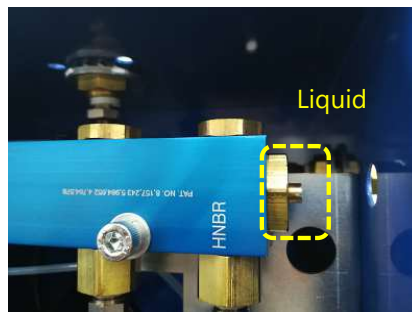

Maximum stroke



Minimum stroke

#### ② Frequency Generator

##### ● How to use

1. With a stop watch determine the length of the pump cycle in seconds.
2. Use a small flat screwdriver to adjust the frequency generator, counterclockwise increases the cycle speed and clockwise decreases the speed.

##### ● Notes

- Frequency generator shows ROUGH guideline.
- With the stop watch continue to monitor the pump cycle until the desired cycle rate is reached.



Frequency Generator

**■ QUANTITY of LUBRICANT (Pump cycle in seconds and liquid control screw)**

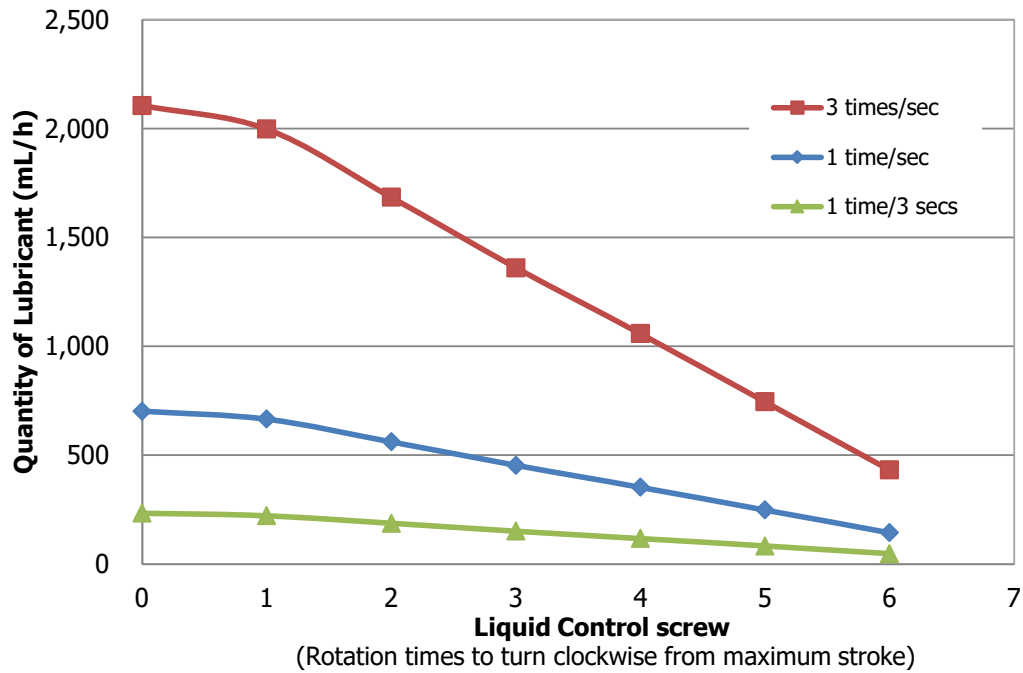

Pump stroke by Liquid flow control	Lubricant (mL/h)			
	Pump cycle in seconds by Frequency Generator			
	1time/3sec (0.3Hz)	1time/sec (1Hz)	3times/sec (3Hz)	
max stroke--> <b>0</b>	234	702	2106	
<b>1</b>	222	666	1998	
Rotation times to turn clockwise from maximum stroke.	<b>2</b>	187	562	1685
<b>3</b>	151	454	1361	
<b>4</b>	118	353	1058	
<b>5</b>	83	248	745	
min stroke--> <b>6</b>	48	144	432	

\*The table shows reference because the quantity of output would be effected by any other external factors.

**■ AIR FLOW CONTROL**

Air Flow Control is adjustable to set air control valve.

**③ Air control valve**

● How to use

1. Pulling blue knob to unlock
2. Counterclockwise increases the air flow and clockwise decreases the air flow.

\*The dial shows amount of air flow rate.

3. Push blue knob to lock

● Notes

Air flow rate increase makes some effect on cooling feature and/or chip removal.



## TROUBLESHOOTING

### Read instructions before investigation

1. Check supply air runs 0.4MPa over and inlet port opened.
2. Check Lubricant filled in tank.
3. Please follow below procedure to clarify what causes problems.

### Procedures to analysis problems

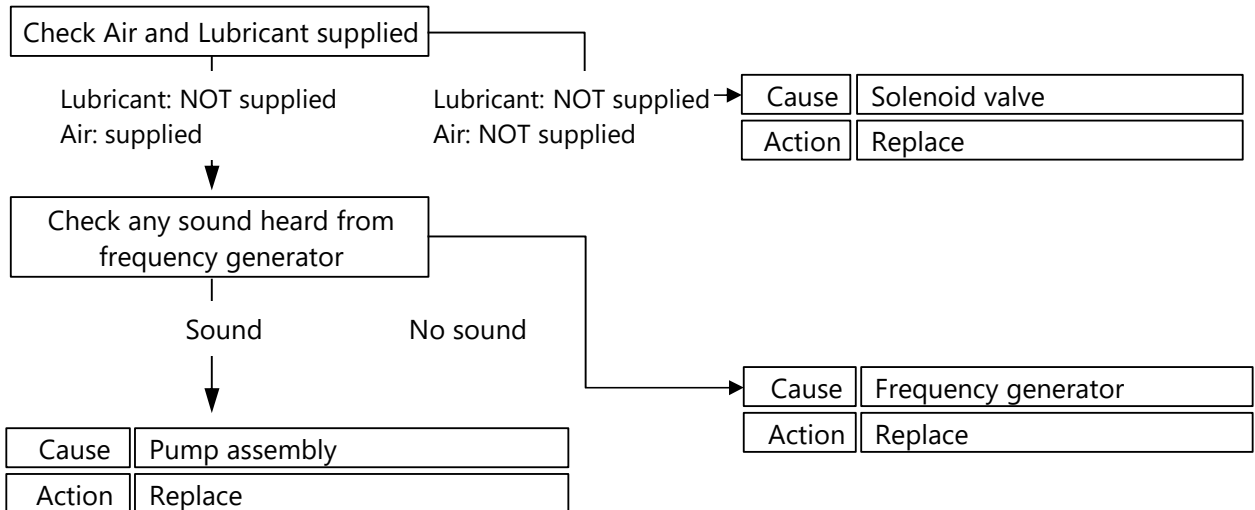

**Please feel free to contact sales distributor to order and replace parts**

### Table of broken components to clarify

Output	Air supplied	No Air output
Lubricant supplied	No problem	<ul style="list-style-type: none"> <li>• Check air control valve</li> <li>• Check air tubing broken</li> </ul>
No Lubricant output	<ul style="list-style-type: none"> <li>• Frequency generator broken</li> <li>• Pump assembly broken</li> <li>• Lubricant line is missing from pump</li> </ul>	<ul style="list-style-type: none"> <li>• Solenoid valve broken</li> </ul>

# SPECIFICATIONS

BX2HF>-S00-00-0-1900-0

- Pumps : 2
- Control : Electric solenoid valve (Select voltage and lead wire length)
- Nozzle : (case sensitive)
- Hose : Braided Hose(φ8,φ10 soft nylon tubing selectable)
- Liquid reservoir : 1,900mL no float switch (4L tank and float switch available)
- Option : No air filter regulator, equip magnets to mount box

( ) shows expected size.  
Please see actual scale in detail.

⑫ Double hose: connected to nozzle (sales unit: m)  
Lubricant line  
Air line  
O.D.: φ10.5mm  
I.D.: φ6.0mm  
Material - Nylon  
Material - Soft polyvinyl chloride hose  
Min. bend radius - approx. 15mm  
Recommend hose nipple - φ7

Min. radius bend condition: room temperature and no distortion

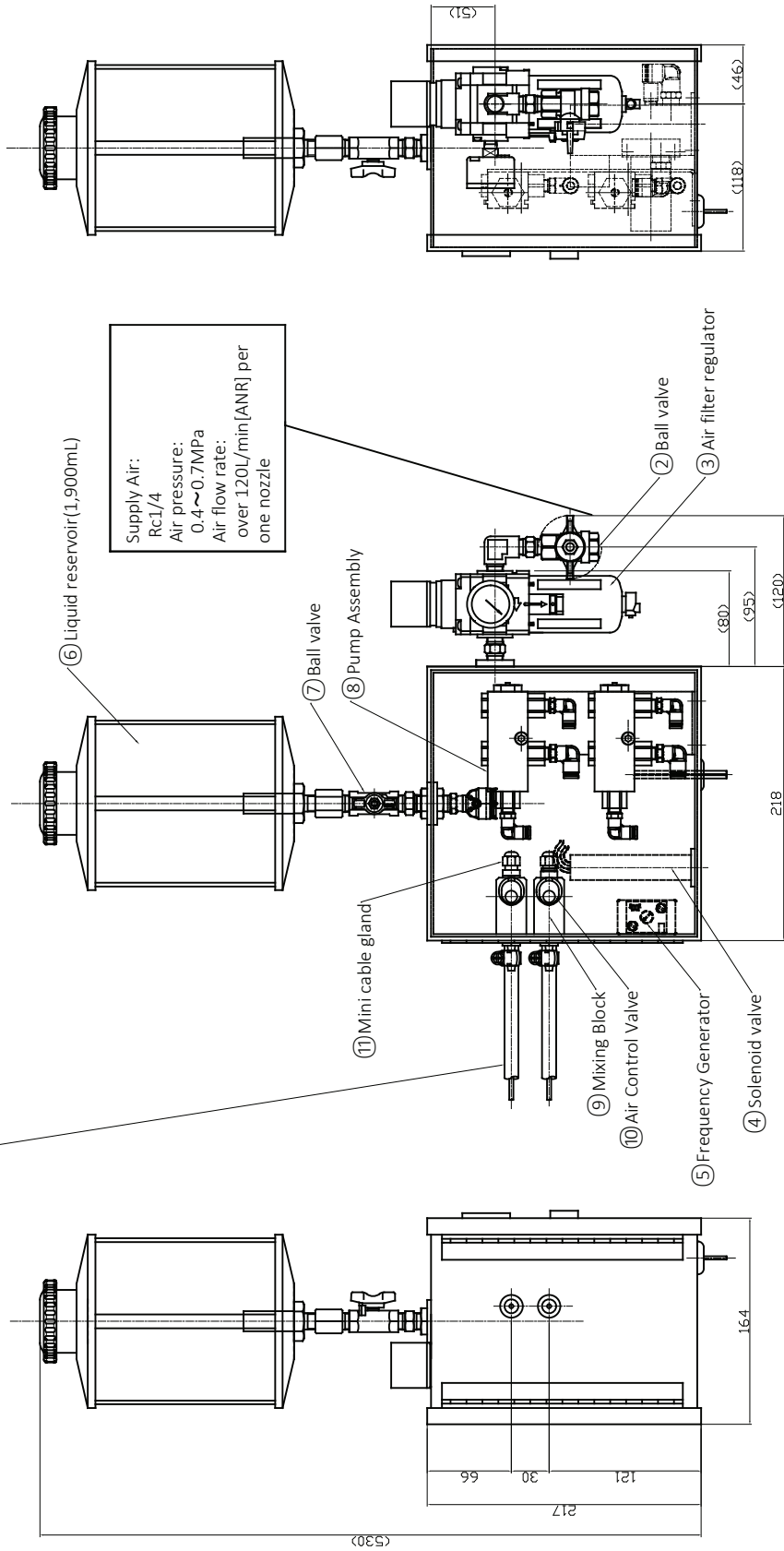
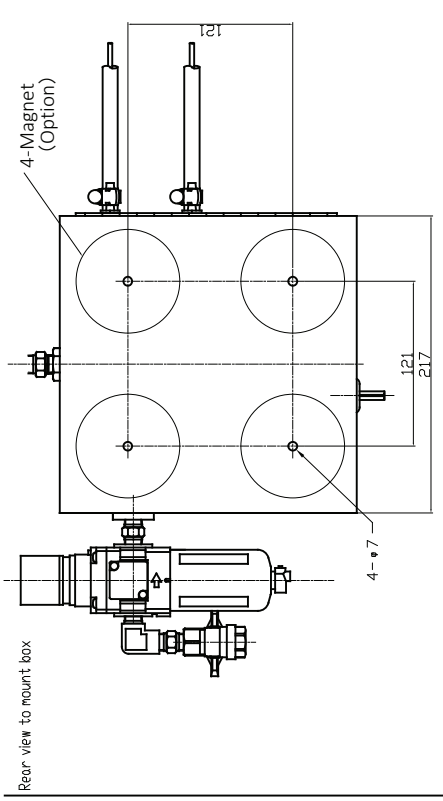

# Diagram

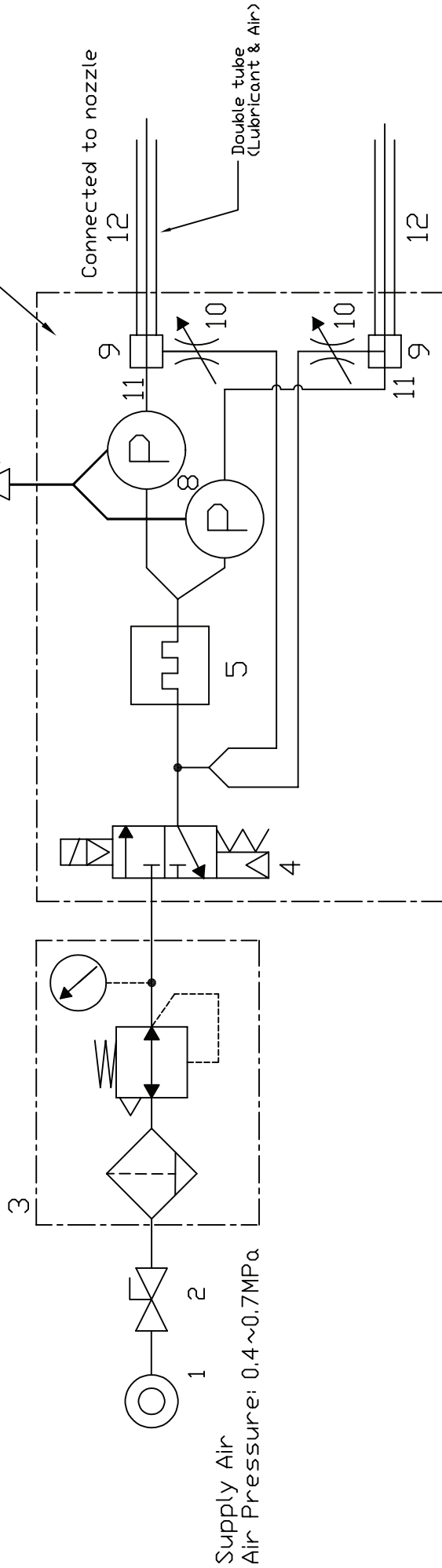

No.	Parts Name	Qty.	Manufacturer	Model	Remarks
1	Supply air				
2	Ball valve	1	FBC	4415	Manual applicators only
3	Air filter regulator	1	SMC	9728	Gauge and 1/4Nipple equipped
4	Solenoid valve	1	SMC	VQZ312-*YZB1-02	* 5:DC24V,1:AC100V,2:AC200V
5	Frequency Generator	1	FBC	#9707	
6	Liquid Reservoir	1	FBC	Ref (Parts list)	1,900mL / 4L tank
7	Ball valve	1	FBC	4415	
8	Pump assembly	1(2)	FBC	Ref (Parts List)	Water soluble · Straight oil
9	Mixing Block	1(2)	FBC		1 pc per 1 nozzle
10	Air control valve	1(2)	SMC	AS2211FS-01-08S	
11	Mini cable gland	1(2)	Japan AVC	MGB8-04B-ST	
12	Double hose (Lubricant&Air)	1(2)	FBC	#9360 · #9363	Soft nylon tube selectable

## PARTS LIST

Please refer to see parts No. on page 10.

**Model BX-1(2)**

### I. Parts by general manufacturer

No.	Parts Name	Qty	Manufacturer	Model	Remarks
2	Manual on/off valve	1	FBC	4415	Manual applicators only
3	Air filter regulator	1	FBC	9728	Gauge and 1/4Nipple equipped
4	Solenoid valve	1	SMC	VQZ312-5YZB1-02	24VDC
				VQZ312-1YZB1-02	100VAC
				VQZ312-2YZB1-02	200VAC
7	Ball valve	1	FBC	4415	
10	Air control valve	1(2)	SMC	AS2211FS-01-08S	
11	Mini cable gland	1(2)	Japan AVC	MGB8-04B-ST	

### II. Parts by FUJI BC

No.	Parts Name	Qty	Manufacturer	Model	Remarks	
5	Frequency generator	1	FBC	9707	Frequency generator + base plate	
6	Liquid reservoir 1900mL	1	FBC	8006	1900mL	
				8006A-U1/U5	1900mL (Float switch, Upper ON)	
				8006A-D1/D5	1900mL (Float switch, Down ON)	
	Liquid tank 4L	1	(*1)	TANKH	4L TANK	
				TANKHL-U1/U5	4L TANK (Float switch, Upper ON)	
				TANKHL-D1/D5	4L TANK (Float switch, Down ON)	
8	Pump assembly	1(2)	FBC	BXP-F1-EX		
12	Double tube Braided hose	1(2)	FBC	9360/3L		
12	Double tube Softnylon OD:8	1(2)		(*2)	9360/3L-T8	Air hose: OD 8mm /ID:6mm
12	Double tube Softnylon OD:10	1(2)		9360/3L-T10	Air hose: OD10mm/ID:7.5mm	
	Nozzle	1(2)	FBC	CPNZ	Copper nozzle	
				SSNZ	Stainless nozzle	
				LLMB	Loc-Line nozzle with magnet base	
				CPMB	Copper nozzle with magnet base	
				SSMB	Stainless nozzle with magnet base	

(\*1) Please select lead wire length (U1,D1=1m / U5,D5=5m)

(\*2) Sales unit: metric

**Unauthorized copying and replication of the contents of this guide, text and images are strictly restricted. All Rights Reserved.**

## NOTES

---

---

---

---

---

---

---

Model Number: \_\_\_\_\_

Serial Number: \_\_\_\_\_

Purchase Date: \_\_\_\_\_

Lubricant: \_\_\_\_\_

# フジBC技研 株式会社

本社 / 〒467-0851 愛知県名古屋市瑞穂区塩入町3-1  
TEL (052)824-7784 FAX (052) 819-5474

最新の製品情報はホームページをご覧ください。 [www.fuji-bc.com](http://www.fuji-bc.com)

**FUJI BC ENGINEERING CO., LTD.**  
3-1, SHIOIRI-CHO, MIZUHO-KU, NAGOYA, 467-0851 JAPAN  
PHONE:+81-52-824-7784 FAX:+81-52-819-5474

Rev: 2026/07/01