

151S 外径溝入れ 突切り

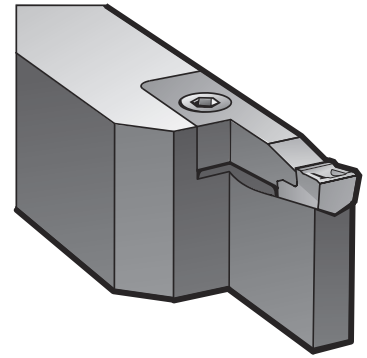

NEW カットピア (CUTPIA) による日本生まれの新しいホルダ (型番末尾 N)

- ・ミルコーナ製と同等以上の品質で、価格を抑えました。
- ・ミルコーナと互換性があり、ミルコーナ/カットピアインサートが使用可能。

適用インサート	型番 型番末尾 N : CUTPIA	在庫	単価	寸法 (mm)					クランプ		クランプ スクリュー 	スプリング 	レンチ
				H	B	L	L ₁	B ₁	R151S 用	L151S 用			
									SHR	SHL			
				R/L151S 共通									
3	R/L 151S-2020x16x3T	○	21,390	20	20	125	16	3	SHR163F	SHL163F	F6S415	-	NY2.5
	R/L 151S-2020x16x3N		16,740	20	20	125	16	3	SHR163FN	SHL163FN	F6S415	-	T20
	R/L 151S-2020x20x3	○	22,510	20	20	125	20	3	SHR203M	SHL203M	F6S418	BF04M	NY2.5
	R/L 151S-2020x20x3N	○	17,620	20	20	125	20	3	SHR203MN	SHL203MN	F6S418	BF04N	T20
	R/L 151S-2516x13x3	○	24,320	25	16	140	13	3	SHR133	SHL133	F6S411	-	NY2.5
	R/L 151S-2516x13x3N		19,030	25	16	140	13	3	SHR133N	SHL133N	F6S411	-	T20
	R/L 151S-2516x20x3		25,160	25	16	140	20	3	SHR203M	SHL203M	F6S418	BF04M	NY2.5
	R/L 151S-2516x20x3N		19,690	25	16	140	20	3	SHR203MN	SHL203MN	F6S418	BF04N	T20
	R/L 151S-2525x20x3	◎	24,730	25	25	150	20	3	SHR203M	SHL203M	F6S418	BF04M	NY2.5
	R/L 151S-2525x20x3N	◎	19,350	25	25	150	20	3	SHR203MN	SHL203MN	F6S418	BF04N	T20
	R/L 151S-3225x20x3		27,230	32	25	170	20	3	SHR203M	SHL203M	F6S418	BF04M	NY2.5
	R/L 151S-3225x20x3N		21,310	32	25	170	20	3	SHR203MN	SHL203MN	F6S418	BF04N	T20
4	R/L 151S-2012x20x4		20,840	20	12	125	20	4-4.5	SHR204MT	SHL204MT	F6S418	BF04M	NY2.5
	R/L 151S-2012x20x4N		16,310	20	12	125	20	4-4.5	SHR204MTN	SHL204MTN	F6S418	BF04N	T20
	R/L 151S-2020x20x4	◎	22,510	20	20	125	20	4-4.5	SHR204MT	SHL204MT	F6S418	BF04M	NY2.5
	R/L 151S-2020x20x4N		17,620	20	20	125	20	4-4.5	SHR204MTN	SHL204MTN	F6S418	BF04N	T20
	R/L 151S-2516x20x4		25,160	25	16	140	20	4-4.5	SHR204MT	SHL204MT	F6S418	BF04M	NY2.5
	R/L 151S-2516x20x4N		19,690	25	16	140	20	4-4.5	SHR204MTN	SHL204MTN	F6S418	BF04N	T20
	R/L 151S-2525x20x4	◎	24,730	25	25	150	20	4-4.5	SHR204MT	SHL204MT	F6S418	BF04M	NY2.5
	R/L 151S-2525x20x4N	◎	19,350	25	25	150	20	4-4.5	SHR204MTN	SHL204MTN	F6S418	BF04N	T20
5	R/L 151S-2020x20x5	◎	22,510	20	20	125	20	5	SHR205MT	SHL205MT	F6S418	BF04M	NY2.5
	R/L 151S-2020x20x5N		17,620	20	20	125	20	5	SHR205MTN	SHL205MTN	F6S418	BF04N	T20
	R/L 151S-2516x20x5		25,160	25	16	140	20	5	SHR205MT	SHL205MT	F6S418	BF04M	NY2.5
	R/L 151S-2516x20x5N		19,690	25	16	140	20	5	SHR205MTN	SHL205MTN	F6S418	BF04N	T20
	R/L 151S-2525x20x5	◎	24,730	25	25	150	20	5	SHR205MT	SHL205MT	F6S418	BF04M	NY2.5
	R/L 151S-2525x20x5N	◎	19,350	25	25	150	20	5	SHR205MTN	SHL205MTN	F6S418	BF04N	T20
6	R/L 151S-2516x20x6		25,160	25	16	140	20	6-7.5	SHR206MT	SHL206MT	F6S418	BF04M	NY2.5
	R/L 151S-2516x20x6N		19,690	25	16	140	20	6-7.5	SHR206MTN	SHL206MTN	F6S418	BF04N	T20
	R/L 151S-2525x20x6	◎	24,730	25	25	150	20	6-7.5	SHR206MT	SHL206MT	F6S418	BF04M	NY2.5
	R/L 151S-2525x20x6N	◎	19,350	25	25	150	20	6-7.5	SHR206MTN	SHL206MTN	F6S418	BF04N	T20
	R/L 151S-3225x20x6	○	27,230	32	25	170	20	6-7.5	SHR206MT	SHL206MT	F6S418	BF04M	NY2.5
	R/L 151S-3225x20x6N	○	21,310	32	25	170	20	6-7.5	SHR206MTN	SHL206MTN	F6S418	BF04N	T20
	R/L 151S-3225x32x6	◎	29,440	32	25	170	32	6-7.5	SHR326MT	SHL326MT	F6S519	BF05M	NY3
	R/L 151S-3225x32x6N	◎	23,040	32	25	170	32	6-7.5	SHR326MTN	SHL326MTN	F6S518	BF05N	T25

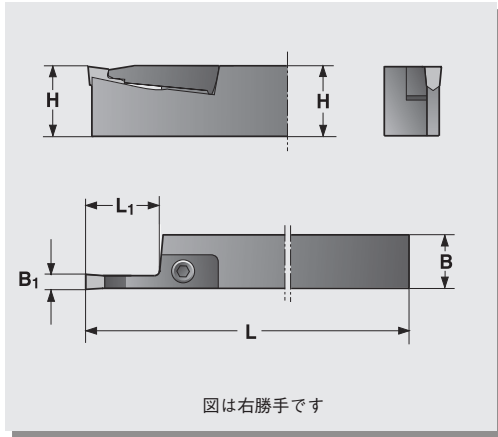

適用インサート	型番 L151S R151S 型番末尾 N : CUTPIA	在庫	単価	寸法 (mm)					クランプ		クランプ スクリュー	スプリング	レンチ
				H	B	L	L ₁	B ₁	R151S 用	L151S 用			
									SHR	SHL			
								R/L151S 共通		SHN			
8	R/L 151S-2525x20x8	◎	32,090	25	25	150	20	8-9	SHR208MT	SHL208MT	F6S519	BF05M	NY3
	R/L 151S-2525x20x8N	○	25,110	25	25	150	20	8-9	SHR208MTN	SHL208MTN	FTS518	BF05N	T25
	R/L 151S-3225x20x8		33,760	32	25	170	20	8-9	SHR208MT	SHL208MT	F6S519	BF05M	NY3
	R/L 151S-3225x20x8N		26,420	32	25	170	20	8-9	SHR208MTN	SHL208MTN	FTS518	BF05N	T25
	R/L 151S-3225x30x8	◎	35,420	32	25	170	30	8-9	SHR308MT	SHL308MT	F6S519	BF05M	NY3
	R/L 151S-3225x30x8N	◎	27,720	32	25	170	30	8-9	SHR308MTN	SHL308MTN	FTS518	BF05N	T25
	R/L 151S-4032x40x8	◎	41,670	40	32	200	40	8-9	SHR408M	SHL408M	F6S526	BF05M	NY3
	R/L 151S-4032x40x8N	○	32,610	40	32	200	40	8-9	SHR408MN	SHL408MN	FTS525	BF05N	T25
1 ¹⁾	R/L 151S-4032x50x8	○	44,590	40	32	200	50	8-9	SHN8T		F6S418	BF04T	NY2.5
	R/L 151S-4032x50x8N	◎	34,900	40	32	200	50	8-9	SHN8TN		FTS416A	BF04N	T20
10	R/L 151S-3225x30x10		35,560	32	25	170	30	10-11	SHR3010MT	SHL3010MT	F6S519	BF05M	NY3
	R/L 151S-3225x30x10N	○	27,830	32	25	170	30	10-11	SHR3010MTN	SHL3010MTN	FTS518	BF05N	T25
	R/L 151S-4032x30x10	○	41,670	40	32	200	30	10-11	SHR3010MT	SHL3010MT	F6S519	BF05M	NY3
	R/L 151S-4032x30x10N	○	32,610	40	32	200	30	10-11	SHR3010MTN	SHL3010MTN	FTS518	BF05N	T25
	¹⁾ R/L 151S-4032x50x10	○	44,440	40	32	200	50	10-11	SHN10T		F6S518T	BF05T	NY3
	¹⁾ R/L 151S-4032x50x10N	◎	34,780	40	32	200	50	10-11	SHN10TN		FTS518A	BF05N	T25
12	¹⁾ R/L 151S-4032x50x12	○	45,560	40	32	200	50	12	SHN12T		F6S519	BF05T	NY3
	¹⁾ R/L 151S-4032x50x12N	◎	35,650	40	32	200	50	12	SHN12TN		FTS518	BF05N	T25

◎ : 左右両勝手在庫 ○ : 右勝手のみ在庫 空欄 : メーカー (海外) または受注生産

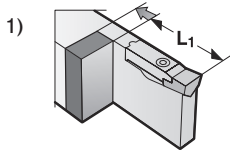

1)ホルダを修正することにより、より深い切込が可能です。

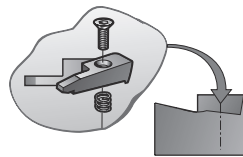

レンチ以外のパーツはホルダに付属しています。