

FBC

ENVIRONMENT
+
PRODUCTION

Bluebe Accu-Lube®

The Natural Choice in Metalworking Lubricants & Equipment



FUJI BC ENGINEERING CO.,LTD.



FBC

ENVIRONMENT+PRODUCTION

Company Profile

- 1972 ○ Our company was established for importing cutting tools in 1972 as “FUJI KOEKI CO., LTD.”
- 1979 ○ In 1989, we started business dealing in MQL applicators and lubricants. These products were developed in 1979 by Mr. Gaunt, who was working for the Boeing Company. They were developed for drilling and reaming titanium material. He then established his own company and the products were sold under the brand name of “Accu-Lube.” Then, in 1989, the product became available in Japan under the brand name, “Bluebe.”
- 1989 ○
- 1993 ○ In 1993, production of external applicators started in Japan. In 1997, we developed internal applicators, named “EcoBooster.” In 2002, we changed our company name to “FUJI BC ENGINEERING CO., LTD.”
- 1997 ○
- 2002 ○
- 2010 ○ In 2010, we created a new company logo, “FBC,” and introduced new lubricants that we developed ourselves under the brand name of “Mquel” in addition to the “Bluebe” brand.
- 2014 ○ Our head office is located in Nagoya and three branches are at other locations in Japan. We also have an overseas subsidiary named “BLUEBE (SHANGHAI) ENVIRONMENTAL TECHNOLOGY CO., LTD.” in Shanghai, China.

What FUJI BC ENGINEERING CO., LTD. (FBC) does?

We carry out the import and sales of cutting tools and vacuum brazing machines, as well as the design, manufacture, and sales of MQL applicators, metalworking lubricants, and specialized MQL tools. FBC has been the industry leader providing total MQL engineering.

FUJI BC ENGINEERING CO., LTD. is a self-declaration company of ISO14001

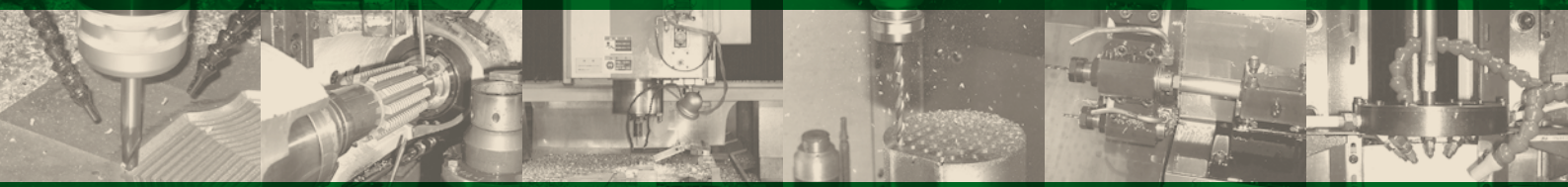

What is the semi-dry machining?

This term refers to the metal cutting carried out with atomized droplets of high lubricity cutting fluid applied in a minimum amount to the tool's cutting edge with pinpoint accuracy. The usage of droplets is extremely small; from 4 ml to 30 ml per hour. Machining can be achieved in virtually dry conditions.

This process is also known as "MQL (Minimum Quantity Lubrication)," "Near Dry Cut," or "Near Dry Machining."

Though there are differences in counting units, the amount of fluid supplied to a machining point is about a sixty-thousandth compared to traditional wet machining processes. Sophisticated technology is required to supply such a small amount of high lubricity fluid to an exact point with precise on/off response.

What are the advantages of MQL machining?

Its advantages include:

- 1 Elimination or reduction of coolants, improving the working environment and contributing to the 5-S campaign
- 2 Increase productivity, such as extended tool life and improved machining efficiency
- 3 Cost saving, including power consumption, waste oil disposal, incidentals, and CO2 reduction
- 4 Conserve space enabling significant reduction in facility cost
- 5 Reduce facility cost including maintenance
- 6 Conformance to various laws and regulations on substances of concern, including ISO14001 and fire laws
- 7 Reduction of fire risk by fire resistant base oil



Internal Applicators



External applicator



Genuine lubricants



Global environment



MK (general-purpose type)

»»» Applicator selection

Types of Bluebe applicators

External applicator

- **Model FK** : Standard type
- **Model JK** : Compact type
- **Model BK** : For precision machining type
- **Model MK** : General –purposes type

Internal applicator

EcoBooster

- **Model EB3** : BASIC series
- **Model EB3P/EB7P** : P series
- **Model EB3EP/EB7EP** : EP series
- **Model EB7VP/EB7EP(F)** : Custom-ordered special type

External applicator

- Atomized droplets of lubricant are supplied through nozzles outside the cutting tool.
- A coaxial tube is used to mix lubricant and air at the tip of the nozzle.
- A stable supply of droplets of lubricant can be achieved with precise on/off response.
- An applicator can be retrofitted easily to equipment already in use.
- The amount of air and the amount of lubricant can be controlled individually (except for the model BK).

Applicable equipment

• Lathes (NC or conventional) • NC milling machines (without ATC) • drilling machines • radial drilling machines • hobbing machines • broaching machines • rolling machines • circular saws • band saws • stamps etc.

Model FK



Model JK



Model BK



Model MK

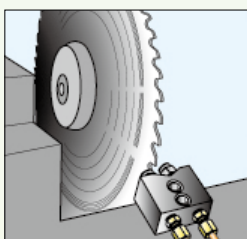

Circular sawing

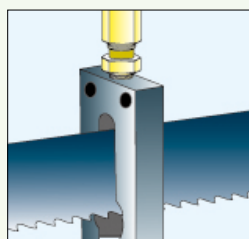

Band sawing

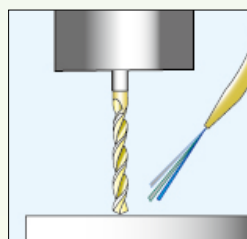

Milling machines

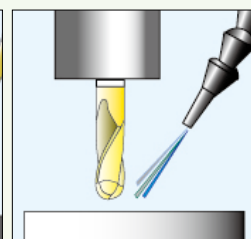

External Applicator Components & Operating Instructions

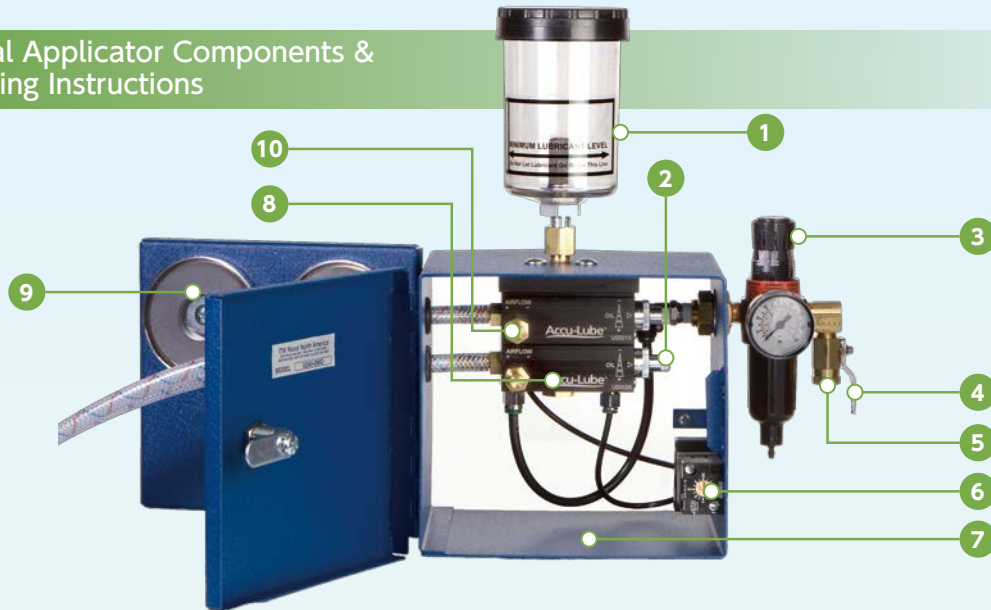

1 Lubricant Reservoir

Lightweight, durable polycarbonate reservoir. Replacement reservoirs are available in varying sizes..

2 Lubricant Valve

Adjusts the amount of lubricant in each pump stroke.

3 Air Filter Regulator/Pressure Gauge

Helps prevent particles and water from entering the applicator through the air lines..

4 On/Off Valve

Turns the applicator on and off by controlling the airflow. Applicators come standard with a manual On/Off valve. It is possible to automate this function with a solenoid valve..

5 Air Supply

Bluebe/Accu-Lube Positive Displacement Pumps are powered by air instead of electricity. Minimum of 0.4 Mpa required to operate effectively.

6 Frequency Generator

Primary lubrication control. Regulates the pump cycle rate, works with the Lubricant Valve 2 for precise lubricant application quantity and speed..

7 Steel Security Box

Durable steel box designed with security locks and doors for maximum access and protection.

8 Bluebe/Accu-Lube Positive Displacement Pump

Expert design for precision application of Bluebe/Accu-Lube lubricants.

9 Mounting

Each security box is equipped with mounting holes for installing the applicator permanently to a machine. Magnetic mounts can be added to 1 and 2 nozzle applicators..

10 Airflow Valve

Controls the amount of continuous air that is sent down the air hose to the nozzle.

Mechanism

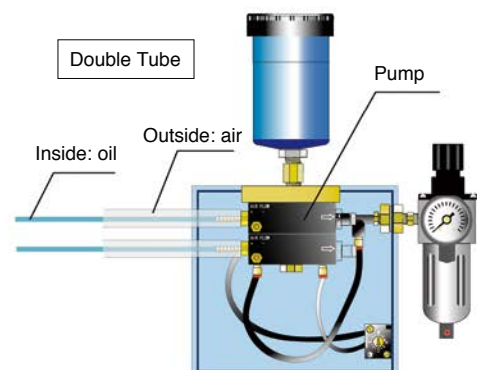
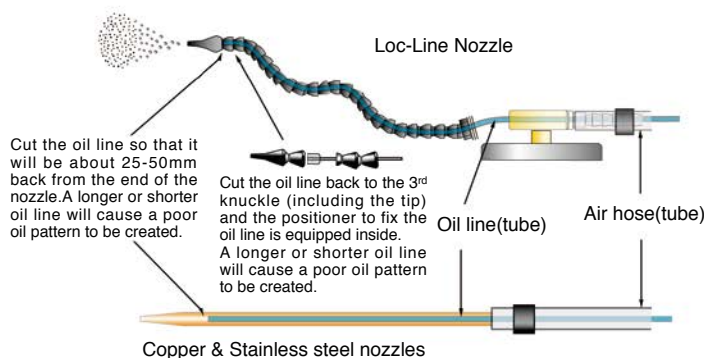

Model **MK** general-purpose type

This model stably supplies a set amount of lubricant from the tip of a nozzle to the machining point. The amount of lubricant can be set in 12 steps by adjusting a dial.



[Specifications]

Supply air	Remove dirt, oil content, and moisture.
Pressure	0.3 to 0.7 MPa
Flow rate	Maximum 240 L/min (ANR)
Connection	Rc1/4
Capacity	2000 mL
Mist outlet	Dia. 6 mm one-touch tube joint
Max discharge rate	Approx. 100 mL/hr (depends on viscosity of lubricant)
Dimensions and weight	280 × 400 × 185 (Width × Height × Depth) Approx. 10 kg (including 2000 ml of lubricant)
Permissible temp	+5 to +50°C

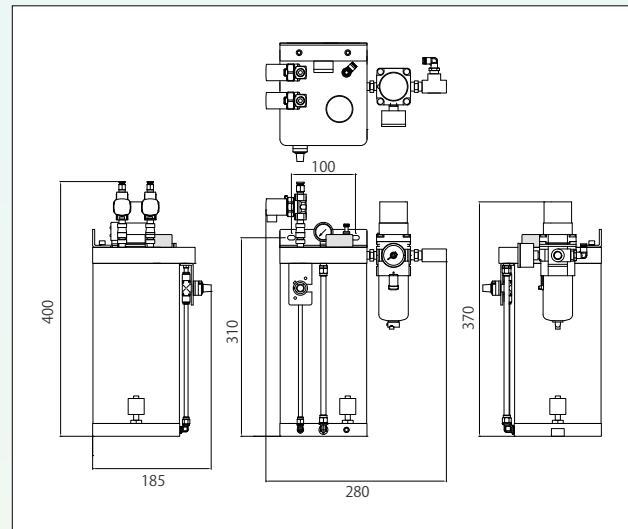

Model **MK**

Model **FK** standard type

The number of nozzles or the number of pumps can be selected, depending on the machining condition.



USA type

Model **BK** for precision machining

This model stably supplies a given amount of lubricant from the tip of a nozzle to the machining point.

The applicator supplies equally-sized lubricant droplets constantly. It enables you to keep a stable machining load on cutting tools and the higher quality parts can be obtained.



[Specifications]

Supply air	Remove dirt, oil content, and moisture.
Pressure	0.4 Mpa \pm 10%
Flow rate	Over 60 L/min (ANR)
Connection	Rc1/4
Capacity	400 mL
Hose Length	Maximum 3m

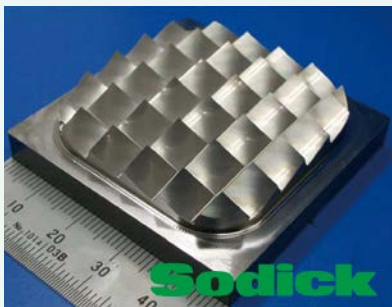

Reflector model



Special nozzle for BK

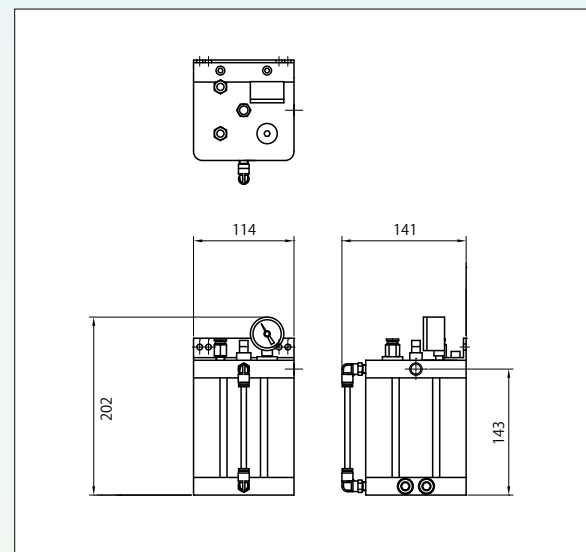

Model **BK**

Model **JK** compact type

A maximum of two nozzles are available.
Simple type with no box.
A box cover is available as an option.



Applicator selection Internal applicator

EcoBooster®

Internal applicator
Through-the-tool Micro Lubrication System
makes NEAR DRY MACHINING(NDM)
A reality in CNC machining.

The EcoBooster from FBC offers a solution to traditional mist applicators that have limitations when used in machining centers with automatic tool changers and CNC lathes. The EcoBooster is specifically designed to eliminate flood coolants on machines with through-the tool coolant system, tool holders with coolant supply, and oil hole tools.

A few milliliter per day of Bluebe/Accu-Lube lubricant eliminates hundreds of liters of traditional flood coolant. The EcoBooster atomizes the Bluebe/Accu-Lube lubricant into micro-droplets, that travel near sonic velocity to the cutting edge without adhering to the machine's through-the tool coolant system. The lubricant is delivered precisely to the cutting edge eliminating wasted or excess lubricant.



- Eliminate Flood Coolant
- Prolongs Tool Life
- Improves Finishes
- Saves Money
- Increases Productivity
- Safer to Workers and Environment

EcoBooster Mechanism(Patented)

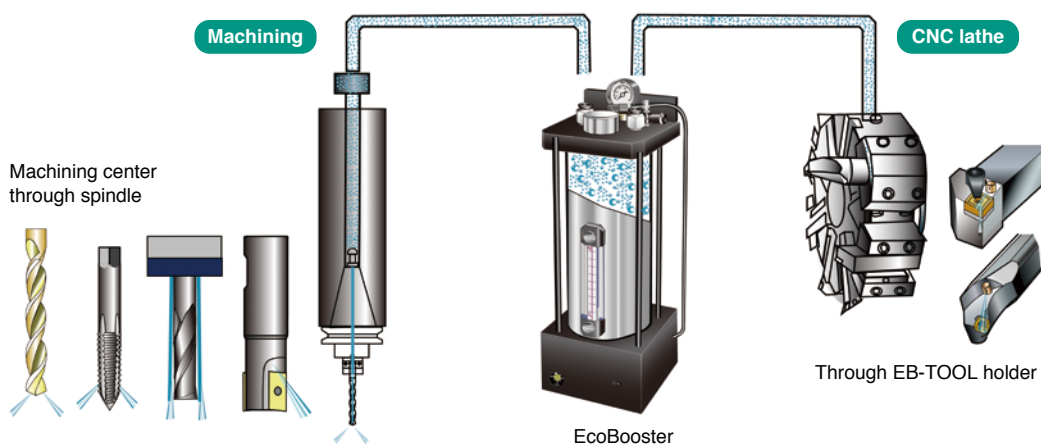

- Atomized droplets of lubricant are generated in the chamber and fed into the machine through existing piping or coolant lines.
 - Drills with oil hole and/or taps with oil hole can be used with through-spindle or a side-through arbor.
 - The internal applicator is used for machining operations which cannot be carried out by the external applicator.
 - The internal applicator has to be selected for turret-type NC lathes since the cutting point moves and the turret rotates.
 - The internal applicator has to be selected for the Machining Center since the length and/or diameter of the tool is changed by the ATC operation. In such a case, an external applicator cannot follow the change in the cutting position with a nozzle.
- However, an external applicator may be applicable to the die and mold machining using an end mill with a fixed length only.

Applicable machines • NC lathes • automatic lathes • machining centers (through-spindle coolant type), and dedicated machines

EcoBooster SELECTION

WHAT IS A DIFFERENCE ? Model EB3 vs EB7

EB3 delivers steady amount of atomized droplets.
Dispense amount on EB7 is proportional to air flow rate.

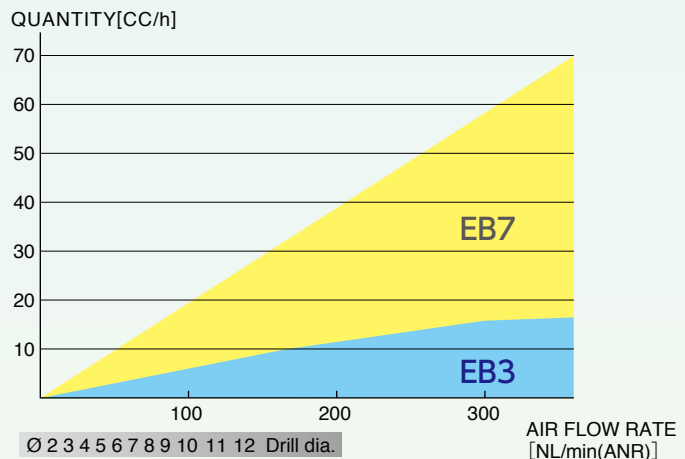

WHAT IS A DIFFERENCE ? Between BASIC, P and EP series?

- **BASIC series : EB3**
Recommended specially for the operation using a similar kind of tools.
- **P series : EB3P and EB7P**
Recommended for the operation using many kinds of tools.
- **EP series : EB3EP and EB7EP**
For the machine tool maker only.

Applicator selection **Internal applicator**

Model **EB3** air pressure manual control type **BASIC** series

This type delivers atomized droplets of lubricant through the through-spindle piping in a Machining Center or through the coolant piping in an NC lathe. The lubricant is applied to the cutting edge by using a nozzle or a tool with oil hole(s).

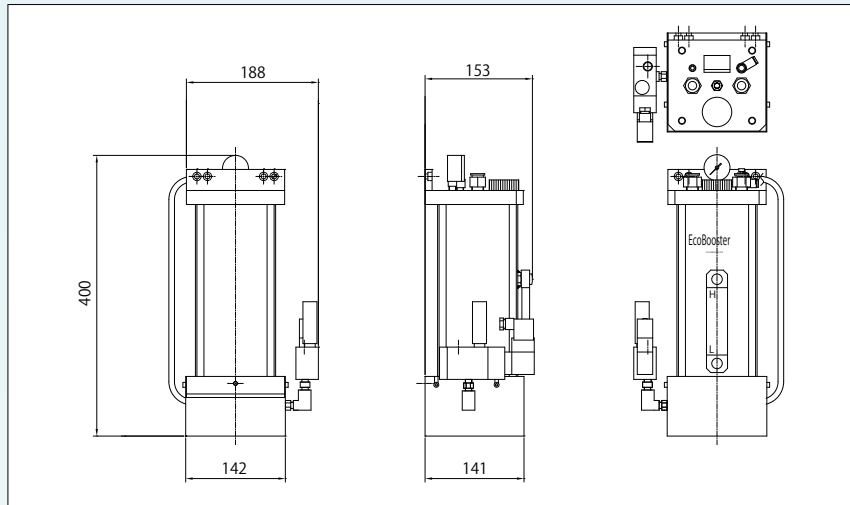

Model **EB3**

Model **EB3P** Model **EB7P** with internal pressure automatic control **P** series

These types offer the feature of internal pressure automatic control in addition to the functionality of EB3 (air pressure manual control type).

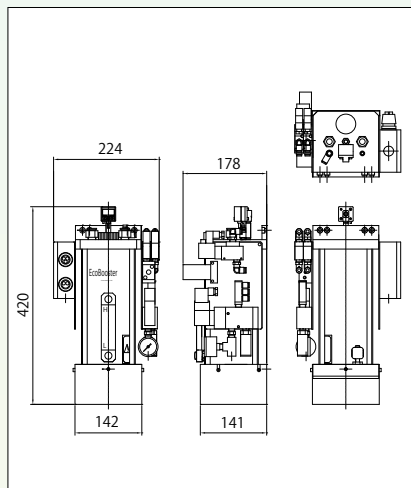

Model **EB3P**

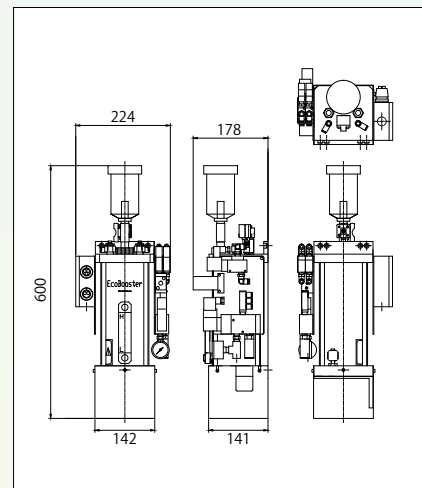

Model **EB7P**

Model **EB3EP** Model **EB7EP**

with automatic control of oil quantity and internal pressure

EP series

These types are designed to be installed on the machines before shipment from the machine tool maker. The applicators offer great flexibility for various types of equipment through manufacturer's own programming.

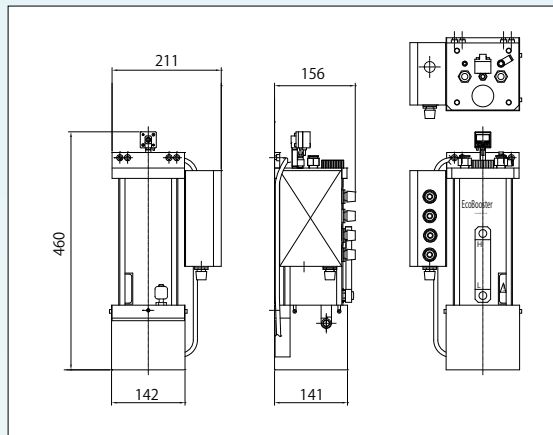

Model **EB3EP**

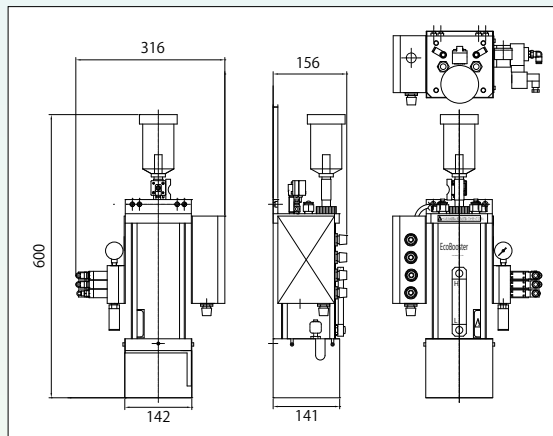

Model **EB7EP**

Model **EB-TOOL**

Turning holder with oil holes for MQL machining. This holder can be used to deliver atomized droplets of lubricant to the machining point from the flank and rake face with pinpoint accuracy. Compared to pipe nozzles, the holder is less affected by chips, enabling more stable machining. Especially in ID turning, EB-TOOL exerts its power to remove chips.

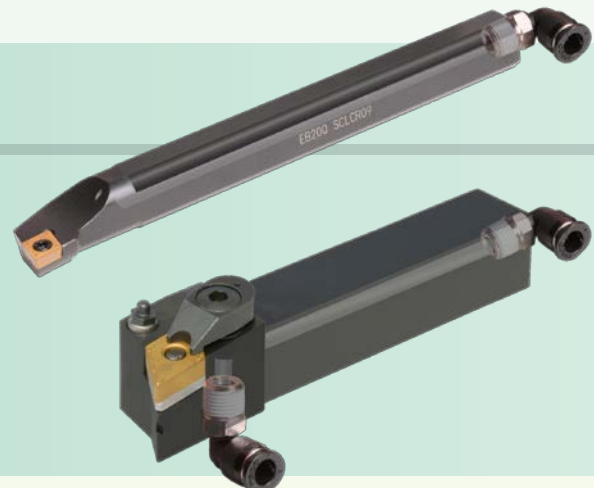

Applicator selection **Internal applicator**

Model **EB7VP** with internal pressure automatic control and fluid can be fed while operating

Continuous run is available by the separated 4,000ml reservoir.

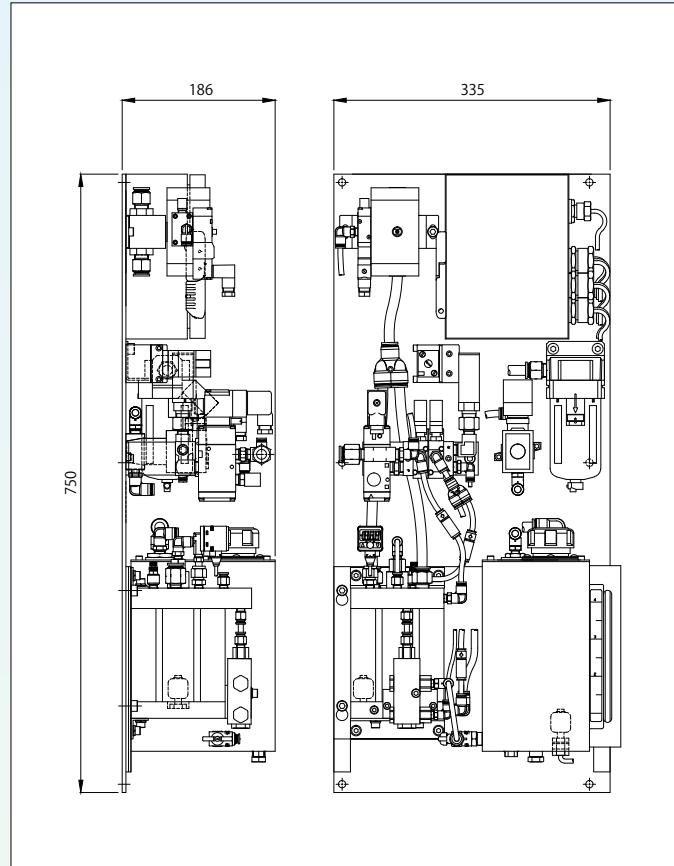

Model **EB7VP**

Model **EB7EP(F)**

Smart and compact floor type EcoBooster EB7EP with a pressure booster boxed.



SIZE: 850×500×830mm

Bluebe

MQuel

Accu-Lube

»» Genuine lubricants

Our metalworking lubricants dedicated to MQL maximally bring out the capability of applicators. These high performance products are friendly to human bodies and the environment.



LB-1



LB-2000

Bluebe LB-1 **Accu-Lube LB-2000**

High lubricity

Bluebe LB-7

High - Medium lubricity

NOTE: LB-7 is available in Asia only. LB-6000 is recommended for the other area.



LB-7



LB-10

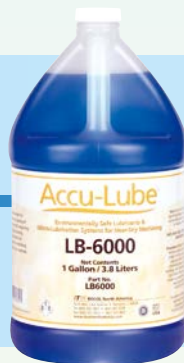

LB-6000

Bluebe LB-10 **Accu-Lube LB-6000**

Medium lubricity and less oil stain

MQuel

Customized lubricants



Examples of machining



Example.1

For NC lathes, basically use our internal applicators (EcoBooster) with EB-TOOLS. For general-purpose lathes and dedicated machines, external applicators can be used in various cases.

Example.2

External applicators can be used for Die and Mold machining with longer cycle time and no tool change operation.



Example.3

Drilling application for small-diameter deep hole is now known as a de facto standard in the auto industry.



Example.4

Select the block nozzle best suited to the saw blade diameter and the mounting space. Mount the nozzle in such a manner that fluid can be applied not only to the cutting edge but also to the sides of the saw blade.



GLOBAL NETWORK

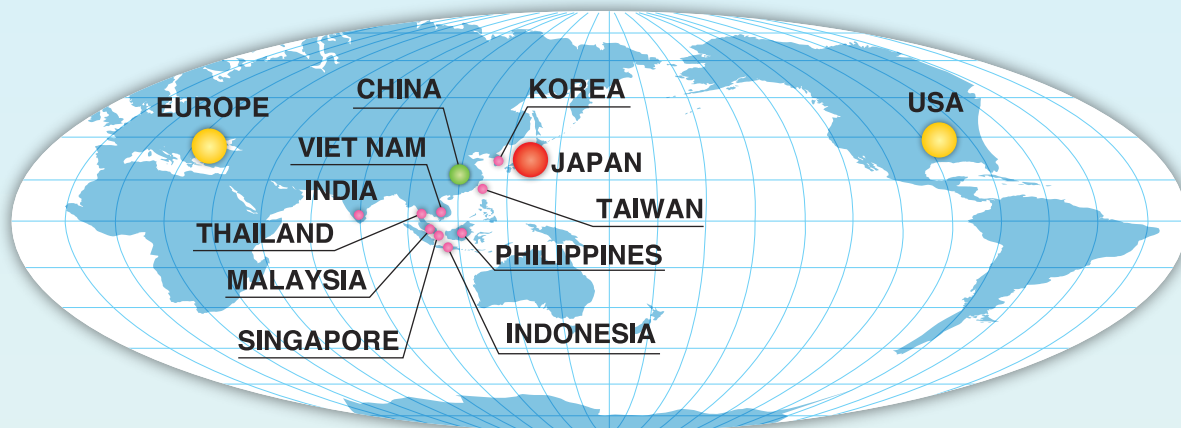

Europe



ACCU-LUBE MANUFACTURING GMBH

Postfach 80 D-75433 Maulbronn,
Germany

TEL : 49-7043-5612

FAX : 49-7043-907098

www.accu-lube.com

USA



ITW PRO BRANDS

805 E. Old 56 Hwy Olathe, Kansas 66061
4647 Hugh Howell Rd. Tucker, Georgia 30084
616 East Industrial St. DeWitt, Iowa 52742

TEL: 1-770-243-8800

FAX: 1-770-243-8899

www.itwprobrands.com

JAPAN



FUJI BC ENGINEERING CO., LTD.

3-1, Shioiri-cho, Mizuho-ku, Nagoya
467-0851 Japan

TEL : 81-52-819-5411

FAX : 81-52-819-5410

www.fuji-bc.com

Distributors in Asia



China

BLUEBE (SHANGHAI) ENVIRONMENTAL TECHNOLOGY CO., LTD.

Room 716-717, No.3, Lane no.58,
East Xinjian Road, Minhang District,
Shanghai, 201100, China

TEL : 86-21-6427-3096 FAX : 86-21-6427-2373



Taiwan

KANDO GROUP CORPORATION

7F., No.8 Lane 83, Sec. 1, Guang Fu Road,
San Chung City, Taipei Hsien 242
Taiwan R.O.C.

TEL : 886-2-2999-0393 FAX : 886-2-2999-0856



Korea

HANSUNG GT CO., LTD.

Gunpocheomdansaneop 1-ro 39, Gunpo-si,
Gyeonggi-do, 15881 South Korea

TEL : 82-31-428-8250 FAX : 82-31-455-0487



Thailand

THAI WORTH CO., LTD.

2/9 Serithai Road, Kwaeng Kannayao,
Khet Kannayao, Bangkok 10230 Thailand

TEL : 66-2736-4560 FAX : 66-2736-4694



Singapore • Malaysia • Indonesia • Philippines • Vietnam

KEMET FAR EAST PTE., LTD.

32, Ang Mo Kio Industrial Park 2,
#02-12, Sing Industrial Complex,
569510 Singapore

TEL : 65-64820990 FAX : 65-64811363



India

ITW INDIA LIMITED

Plot No.34 to 37, Phase-2,
IDA, APIIC, Pashamylaram,
Medak Dist. 502307 India

TEL : 91-8455-224700 FAX : 91-8455-224705

A Green approach to Global solutions

Bluebe

Accu-Lube

MQuel

EcoBooster

FUJI BC ENGINEERING CO.,LTD.

● Main office ●

3-1 Shioiri-cho, Mizuho-ku, Nagoya 467-0851 JAPAN

■ Telephone +81-52-819-5411 ■ Facsimile +81-52-819-5410 ■ URL <http://www.fuji-bc.com>

<http://www.fuji-bc.com>

